

# Homework Helpers

---

# Grade 3 Module 5

Handwritten text or markings along the right edge of the page, possibly bleed-through from the reverse side.

## G3-M5-Lesson 1

1. A beaker is full when the liquid reaches the fill line shown near the top. Estimate the amount of water in the beaker by shading the drawing as indicated.

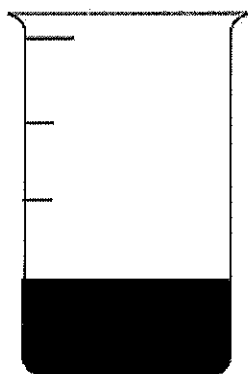

1 fourth

First, I need to partition my whole into 4 equal parts. I can estimate to draw a tick mark halfway between the top and bottom of the beaker and then make tick marks in the middle of each half. After that, I just need to shade 1 of the equal parts.

2. Juanita cut her string cheese into equal pieces as shown below. In the blank below, name the fraction of string cheese represented by the shaded part.



1 fifth

There are 5 equal parts, so each part is 1 fifth. Only 1 fifth is shaded. I can use unit form to name the fraction since I haven't learned numerical form yet.

3. In the space below, draw a small rectangle. Estimate to split it into 6 equal parts. How many lines did you draw to make 6 equal parts? What is the name of each fractional unit?

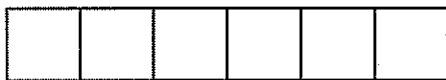

*It took 5 lines to make 6 equal parts.  
Each fractional unit is a sixth!*

To split a rectangle into 6 equal parts, I can draw a line to split it in half and then split each half into 3 equal parts. When I have 6 equal parts, my fractional unit is sixths!

4. Rochelle has a string that is 15 inches long. She cuts it into pieces that are each 5 inches in length. What fraction of the string is 1 piece? Use your strip from the lesson to help you. Draw a picture to show the string and how Rochelle cut it.

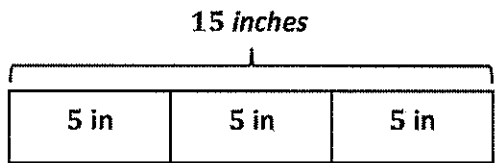

$$15 \div 5 = 3$$

*Each piece is 1 third of the whole string.*

This problem reminds me of division because I'm splitting 15 inches into equal parts that are each 5 inches. I can solve  $15 \div 5$  to find that Rochelle makes 3 pieces. If there are 3 equal pieces, then each piece is a third!

### G3-M5-Lesson 2

1. Circle the strip that is folded to make equal parts.

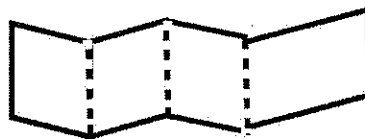
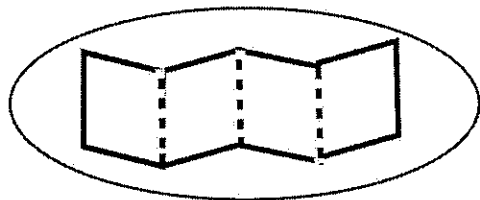

I can see that all of the parts in the strip on the left are the same size. The strip on the right has some small parts and a bigger part.

2. Dylan plans to eat 1 fourth of his candy bar. His 3 friends want him to share the rest equally. Show how Dylan and his friends can each get an equal share of the candy bar.

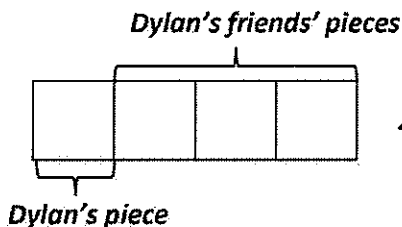

I know that 4 people are sharing the candy bar. I'll draw a fraction strip to represent the candy bar and split it into fourths. I can label Dylan's piece and the pieces that his friends will eat.

3. Nasir baked a pie and cut it into fourths. He then cut each piece in half.

- a. What fraction of the whole pie does each piece represent?

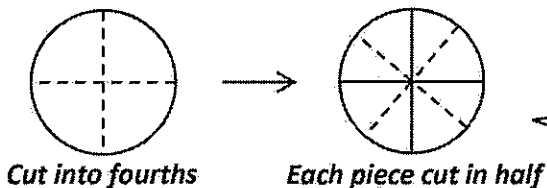

Each piece represents 1 eighth of the whole pie.

First, I should draw the pie and split it into 4 equal pieces. Then, I need to cut each part in half. Once I do that, I see that each piece is an eighth!

- b. Nasir ate 1 piece of pie on Tuesday and 2 pieces on Wednesday. What fraction of the whole pie was NOT eaten?

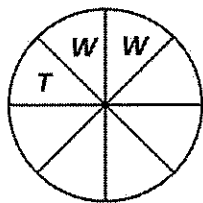

Five eighths of the whole pie was not eaten.

I can draw the pie and label the pieces Nasir ate. He ate 3 out of the 8 pieces, so 5 are left. So, 5 eighths of Nasir's pie is left!

## G3-M5-Lesson 3

1. Each shape is 1 whole. Estimate to divide each into equal parts. Divide each whole using a different fractional unit. Write the name of the fractional unit on the line below the shape.

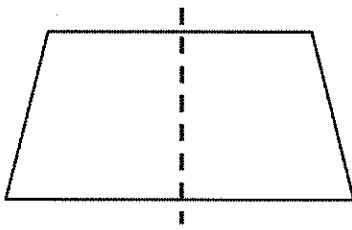

halves

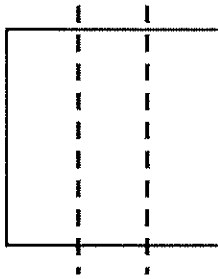

thirds

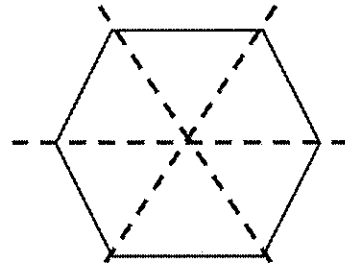

sixths

I can pick a different number of equal parts for each shape and split my shapes to match my choices. Then, I'll name the fractional unit. I have to be careful to make sure the parts are equal. My shapes might look different than my friends' because I get to choose the number of equal parts.

2. Anita uses a whole piece of paper to make a chart showing the school days in 1 week. She draws equal-sized boxes to represent each day. Draw a picture to show a possible chart. What fraction of the chart does each day take up?



Each day takes up 1 fifth of the chart.

There are 5 school days in 1 week, so Anita's chart has 5 boxes that are the same size. Each box represents a day and is 1 fifth of the chart.

### G3-M5-Lesson 4

1. Each shape is 1 whole. Estimate to equally partition the shape, and shade to show the given fraction.



I know that the fraction is 1 half, so I can split each shape into 2 equal parts. Then, I'll shade 1 part in each shape.

2. Each shape represents 1 whole. Match each shape to its fraction.

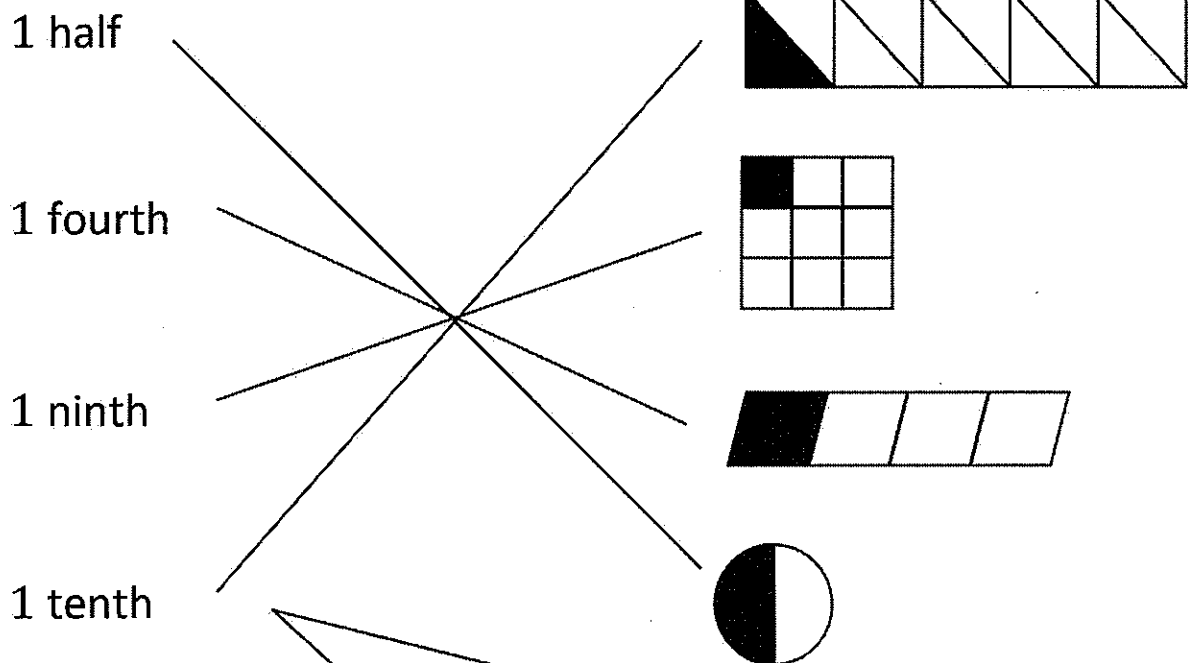

I can look at the fractional unit to figure out how many total parts the shape should have. Then, I look for the shape with that many parts and find the match.

## G3-M5-Lesson 5

1. Fill in the chart. Then, whisper the fractional unit.

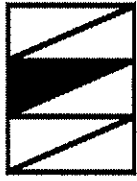
	Total Number of Equal Parts	Total Number of Equal Parts Shaded	Unit Form	Fraction
	6	1	1 sixth	$\frac{1}{6}$

The fractional unit tells the number of equal parts in the whole. Since there are 6 equal parts, I can whisper, "Sixths."

To write a fraction in unit form, I can write the unit as a word. The answer is 1 sixth because I am counting the number of sixths that are shaded.

I can write  $\frac{1}{6}$  for the fraction because 1 equal part is shaded out of a total of 6 equal parts. I know that  $\frac{1}{6}$  is the unit fraction because it names 1 equal part.



If 1 fifth is shaded, then that rectangle must be partitioned into 5 equal parts (fifths). The other rectangle must be partitioned into 8 equal parts (eighths).

2. Draw two identical rectangles. Shade 1 fifth of one rectangle and 1 eighth of the other. Label the unit fractions. Use your rectangles to explain why  $\frac{1}{5}$  is greater than  $\frac{1}{8}$ .

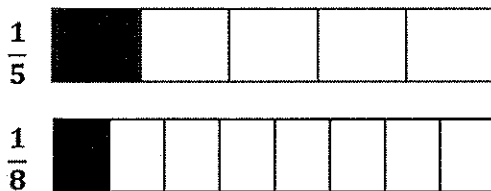

I can draw two identical rectangles and partition one into fifths and the other into eighths. I can shade 1 equal part in each rectangle to show each unit fraction.

$\frac{1}{5}$  is greater than  $\frac{1}{8}$  because both rectangles have 1 equal part shaded, but when the rectangle is cut into 5 equal parts, the parts are bigger than when the rectangle is cut into 8 equal parts.

G3-M5-Lesson 6

1. Complete the number sentence. Estimate to partition each strip equally, write the unit fraction inside each unit, and shade the answer.

3 fourths is written in unit form. I can complete the number sentence by writing it in fraction form:  $\frac{3}{4}$ .

Fourths are the unit, so I'll do my best to draw lines that partition the strip into 4 equal units or parts.

I can label each equal part with the unit fraction:  $\frac{1}{4}$ .

3 fourths =  $\frac{3}{4}$

I can shade 3 copies of the unit fraction,  $\frac{1}{4}$ , to build  $\frac{3}{4}$ .

2. Mr. Stevens buys 8 liters of soda for a party. His guests drink 1 of the 8 liters of soda.
- a. What fraction of the soda do his guests drink?

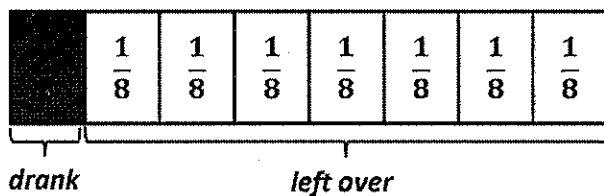

His guests drink  $\frac{1}{8}$  of the soda.

I can draw a whole with 8 equal parts because Mr. Stevens buys a total of 8 liters of soda. I can label each part  $\frac{1}{8}$  to show that it represents 1 of the 8 liters. Then, I can shade 1 part because the guests drink 1 liter.

- b. What fraction of the soda is left?

$\frac{7}{8}$  of the soda is left.

I can just count the unshaded units in my diagram and write a sentence to answer the question.

### G3-M5-Lesson 7

1. Whisper the fraction of the shape that is shaded. Then, match the shape to the amount that is not shaded.

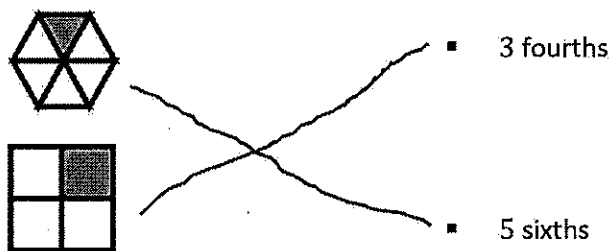

I can count the total number of parts to find the fractional units, fourths and sixths. Then, I can whisper what part is shaded, "1 sixth" and "1 fourth." I can count how many parts aren't shaded and draw lines to match.

2. Mom lights 10 birthday candles on the cake. Alexis blows out 9 candles. What fraction of the birthday candles are still lit? Draw and explain.

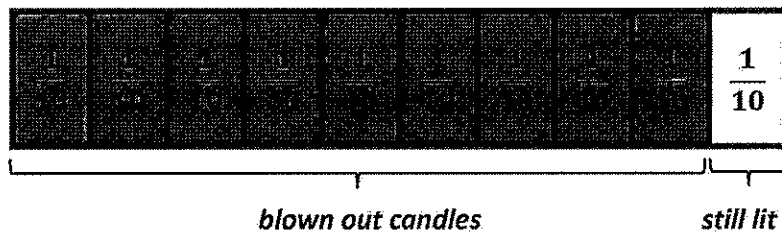

I can draw a whole with 10 parts because there is a total of 10 candles on the cake. I can shade the 9 candles that Alexis blows out and count how many are left.

There are a total of 10 candles, but 9 are blown out. That leaves  $\frac{1}{10}$  of the candles that are still lit.

Alexis blew out all but 1 candle. Since there are 10 candles in all, the fraction of candles still lit is  $\frac{1}{10}$ .

### G3-M5-Lesson 8

1. Show a number bond representing what is shaded and unshaded in the figure. Draw a different model that would be represented by the same number bond.

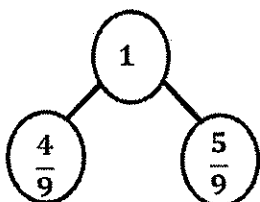
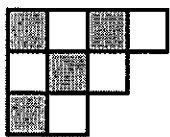

I can draw a number bond that shows 1 whole broken into 2 parts. One part shows how much of the whole is shaded:  $\frac{4}{9}$ . The other part shows how much of the whole is unshaded:  $\frac{5}{9}$ . Together,  $\frac{4}{9}$  and  $\frac{5}{9}$  make 1 whole.

How would I label the number bond if no parts of the whole were shaded? I would still use 1 to label the whole. I could label the shaded parts  $\frac{0}{9}$  and the unshaded parts  $\frac{9}{9}$ . Together,  $\frac{0}{9}$  and  $\frac{9}{9}$  make 1 whole.



I can draw this shape to show 1 whole with  $\frac{4}{9}$  shaded and  $\frac{5}{9}$  unshaded. It can be represented using the same number bond. Lots of other models could work too. Here is one example:



This first part is just like Problem 1.

2. Draw a number bond with 2 parts showing the shaded and unshaded fractions of each figure. Decompose both parts of the number bond into unit fractions.

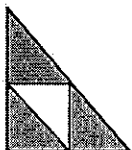

The shaded part of this figure is  $\frac{3}{4}$ , and the unshaded part is  $\frac{1}{4}$ .

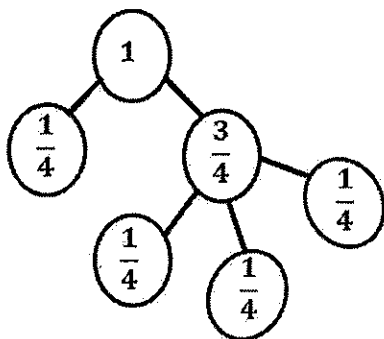

I can draw a number bond with parts of  $\frac{1}{4}$  and  $\frac{3}{4}$ . I know that decomposing is taking apart.  $\frac{1}{4}$  is already a unit fraction, but  $\frac{3}{4}$  is a non-unit fraction. I can decompose  $\frac{3}{4}$  into 3 copies of  $\frac{1}{4}$ . Now both parts of my number bond are written as unit fractions.

I can check my work by looking at all of the unit fractions. There are 4 copies of  $\frac{1}{4}$ , which is the same as  $\frac{4}{4}$ , or 1 whole.

### G3-M5-Lesson 9

1. Each shape represents 1 whole. Fill in the chart.

Each of these wholes is partitioned into halves. So, the unit fraction must be  $\frac{1}{2}$ . Three halves are shaded. I can show that by writing  $\frac{3}{2}$ .

	Unit Fraction	Total Number of Units Shaded	Fraction Shaded
	$\frac{1}{2}$	3	$\frac{3}{2}$

2. Estimate to draw and shade units on the fraction strips. Solve.

7 fourths =  $\frac{7}{4}$

7 fourths is the unit form. I can also write it as  $\frac{7}{4}$ .



Fourths is the fractional unit. I can partition each whole (fraction strip) into fourths and then label each unit to show that it represents  $\frac{1}{4}$ . Seven tells me how many units to shade.

## G3-M5-Lesson 10

1. Each fraction strip is 1 whole. The fraction strips are equal in length. Color 1 fractional unit in each strip. Then, answer the questions below.

I can color one equal part of each whole below.

 $\frac{1}{8}$ 

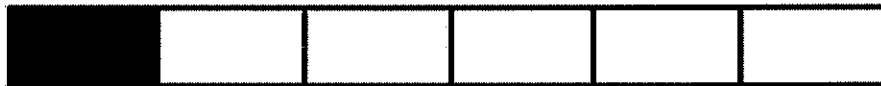
 $\frac{1}{6}$ 

2. Circle *less than* or *greater than*. Whisper the complete sentence.

 $\frac{1}{8}$ 

is less than

 $\frac{1}{6}$ 

is greater than

The fraction strips are equal in length, and they're lined up. I can compare by looking at the fractional units I colored and seeing which one is bigger.  $\frac{1}{8}$  is smaller than  $\frac{1}{6}$ , so it's less. I could also write that as  $\frac{1}{8} < \frac{1}{6}$  or as 1 eighth < 1 sixth. When I read it, I say, "1 eighth is less than 1 sixth."

I can draw fraction strips like the ones in Problem 1 to figure out which fraction is bigger.

3. Jerry feeds his dog  $\frac{1}{5}$  cup of wet food and  $\frac{1}{6}$  cup of dry food for dinner. Does he use more wet food or dry food? Explain your answer using pictures, numbers, and words.

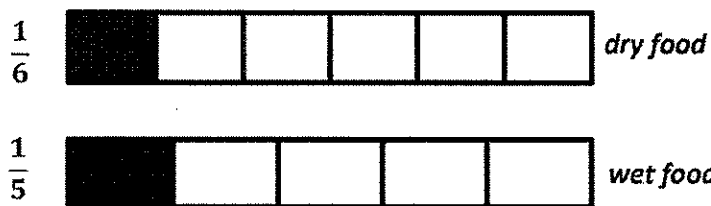

When I draw my fraction strips, they have to be the same size and lined up, or I won't be able to use them to accurately compare the fractions.

*Jerry uses more wet food because  $\frac{1}{5}$  is greater than  $\frac{1}{6}$ . When you cut a whole into more pieces, the pieces get smaller.*

4. Use  $>$ ,  $<$ , or  $=$  to compare.

- a. 1 half  $>$   $\frac{1}{8}$   
 b. 1 fifth  $<$  1 third

I can draw a picture to help me compare the fractions, or I can think about the size of the fractional units. I know that the more equal parts there are, the smaller each part is. That means that halves are bigger than eighths and fifths are smaller than thirds.



## G3-M5-Lesson 11

1. Label the unit fraction. In each blank, draw and label the same whole with a shaded unit fraction that makes the sentence true. There might be more than 1 correct way to make the sentence true.

I need to draw the same rectangle and partition it into equal parts that are greater than  $\frac{1}{3}$  because the sentence reads " $\frac{1}{3}$  is less than \_\_\_\_."

This shape is partitioned into thirds, so  $\frac{1}{3}$  is the unit fraction.

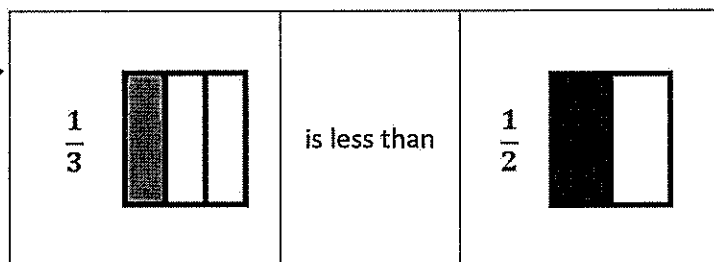

Halves are greater than thirds, so I can draw a rectangle and partition it into halves. I can shade 1 part and label the shaded part as  $\frac{1}{2}$ . Now my sentence says " $\frac{1}{3}$  is less than  $\frac{1}{2}$ ." That's true.

2. Luna drinks  $\frac{1}{5}$  of a large water bottle. Gabriel drinks  $\frac{1}{3}$  of a small water bottle. Gabriel says, "I drank more than you because  $\frac{1}{3} > \frac{1}{5}$ ."

- a. Use pictures and words to explain Gabriel's mistake.

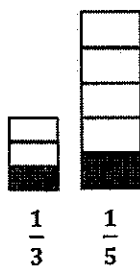

*Gabriel can't compare how much water he and Luna drank. Since the wholes are different,  $\frac{1}{5}$  might be bigger than  $\frac{1}{3}$  like in the picture I drew.*

The important thing I notice is that the water bottles are different sizes. That means the wholes are different, so I can't compare the fractions.

- b. How could you change the problem so that Gabriel is correct? Use pictures and words to explain.

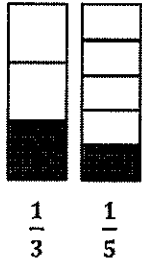

I can draw models for Gabriel and Luna that are the same size. I can partition and shade the models to show  $\frac{1}{3}$  and  $\frac{1}{5}$ . It's easy to compare the fractions now that the wholes are the same.

*I could change the problem to make the wholes the same size. I could say that they both drank water from the same-sized water bottles. Then  $\frac{1}{3}$  is greater than  $\frac{1}{5}$ . When the whole is the same, fifths are smaller than thirds.*

## G3-M5-Lesson 12

1. Each shape represents the given unit fraction. Estimate to draw a possible whole. Draw a number bond that matches.

$$\frac{1}{5}$$



The 5 in the fraction tells me that the unit is fifths, so there are 5 equal parts in the whole. Since this shape is a unit fraction, I can draw 5 copies of it to build my whole. There are lots of different shapes I could draw.

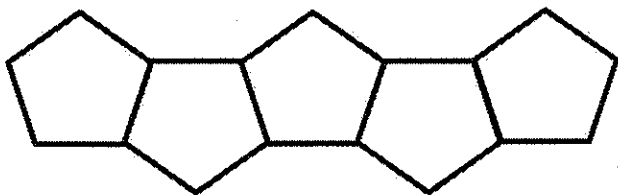

I can make 5 copies of the unit fraction to make a whole. It's important that there are no gaps or overlaps. Overlaps would mean the parts aren't equal. If there were gaps, the whole might not be clear.

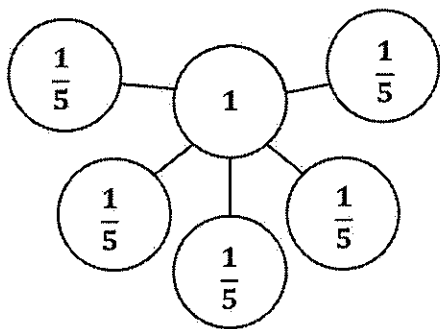

I can draw a number bond that shows the part-whole relationship between the unit fractions and the whole. This matches the drawing because it shows that 5 copies of  $\frac{1}{5}$  make a whole, or 1.

2. Cathy and Laura use this shape  to represent the unit fraction  $\frac{1}{4}$ . They each use it to draw the wholes below. James says they both did it correctly. Do you agree with him? Explain your answer.

Cathy's Shape

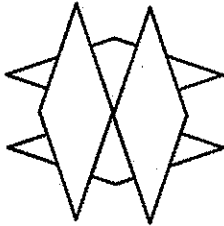

It looks like Cathy drew 4 copies of the shape, but since they're overlapping, it's really hard to tell whether or not the parts are equal sizes.

Laura's Shape

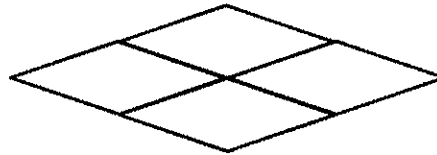

I can easily see in Laura's shape that she drew 4 copies of the shape to make a whole.

**No, I don't agree with James. Cathy's shape has a lot of overlapping, which makes it really hard to see what the whole is. The overlapping also makes it difficult for me to see how many parts make up the whole and whether or not the parts are equal.**

G3-M5-Lesson 13

1.

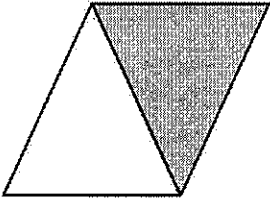
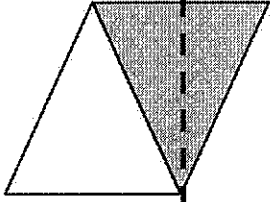
<p>The shape represents 1 whole. Write a unit fraction to describe the shaded part.</p>	<p>The shaded part represents 1 whole. Divide 1 whole to show the same unit fraction you wrote in part (a).</p>
<p>a.</p>  <p style="text-align: right;"><math>\frac{1}{2}</math></p>	<p>b.</p> 

Both triangles make up the whole. Since there are 2 equal parts, that means that the fractional unit is halves and the unit fraction is  $\frac{1}{2}$ . I can write  $\frac{1}{2}$  to represent the shaded part.

This time just the shaded part represents the whole. I have to think about how I can partition just the shaded part into halves since the unit fraction in part (a) is  $\frac{1}{2}$ . Since halves means 2 equal parts, I can draw a dotted line to partition the shaded whole into 2 equal parts.

2.

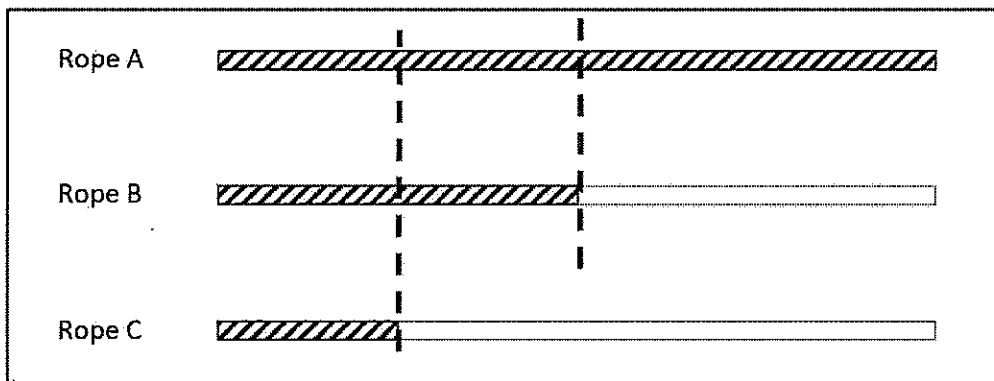

I can draw a dotted line to help me compare the lengths of Ropes A and B. It looks like Rope B is about  $\frac{1}{2}$  the length of Rope A. Half of 10 feet is 5 feet.

a. If Rope A measures 10 feet long, then Rope B is about 5 feet long.

- b. About how many copies of Rope C equal the length of Rope A? Draw a number bond to help you.

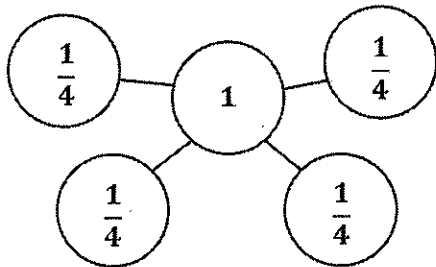

I can draw another dotted line to help me compare the lengths of Ropes C and A. That shows me that Rope C is about  $\frac{1}{4}$  the length of Rope A.

The whole in my number bond, 1, represents the length of Rope A. The 4 parts are the number of copies of Rope C it would take to equal the length of Rope A.

**About 4 copies of Rope C equal the length of Rope A.**

### G3-M5-Lesson 14

1. Draw a number bond for each fractional unit. Partition the fraction strip to show the unit fractions of the number bond. Use the fraction strip to help you label the fractions on the number line. Be sure to label the fractions at 0 and 1.

Thirds

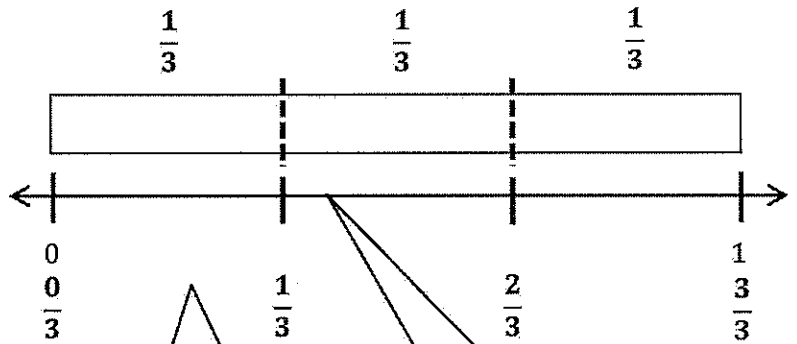
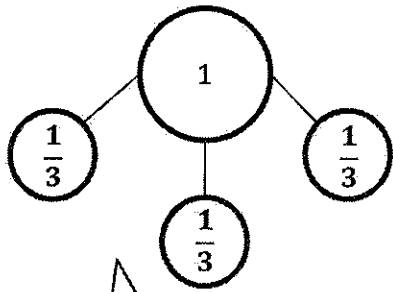

The fractional unit is thirds. The number bond shows that three copies of  $\frac{1}{3}$  make 1 whole.

I partitioned the fraction strip (the rectangle above the number line) into 3 equal parts and labeled each part  $\frac{1}{3}$ . The 3 copies of  $\frac{1}{3}$  on my fraction strip match the 3 copies of  $\frac{1}{3}$  shown by my number bond.

My number line and fraction strip are the same length, so I used the partitions on my fraction strip to help me know where to make tick marks on my number line. Then, I counted thirds from left to right and labeled how many thirds I counted at each tick mark:  $\frac{0}{3}$ ,  $\frac{1}{3}$ ,  $\frac{2}{3}$ ,  $\frac{3}{3}$ .

2. A rope is 1 meter long. Mr. Lee makes a knot every  $\frac{1}{4}$  meter. The first knot is at  $\frac{1}{4}$  meter. The last knot is at 1 meter. Draw and label a number line from 0 meters to 1 meter to show where Mr. Lee makes knots. Label all the fractions, including 0 fourths and 4 fourths. Label 0 meters and 1 meter, too.

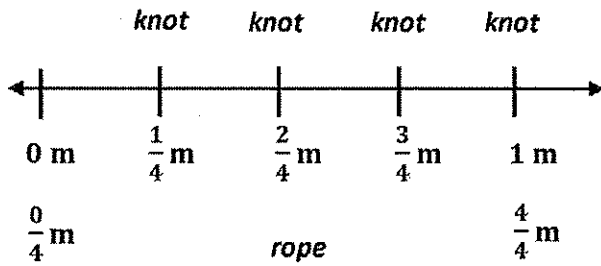

Mr. Lee makes knots every  $\frac{1}{4}$  meter, so his rope must be partitioned into 4 equal parts.

I can draw a number line to represent Mr. Lee's rope and then partition it into 4 equal parts. I can count by fourths from left to right starting at 0, or 0 fourths, and label them at each tick mark: 0 fourths, 1 fourth, 2 fourths, 3 fourths, 4 fourths, or 1 meter.



### G3-M5-Lesson 15

- Estimate to label the given fraction on the number line. Be sure to label the fractions at 0 and 1. Write the fractions above the number line. Draw a number bond to match your number line.

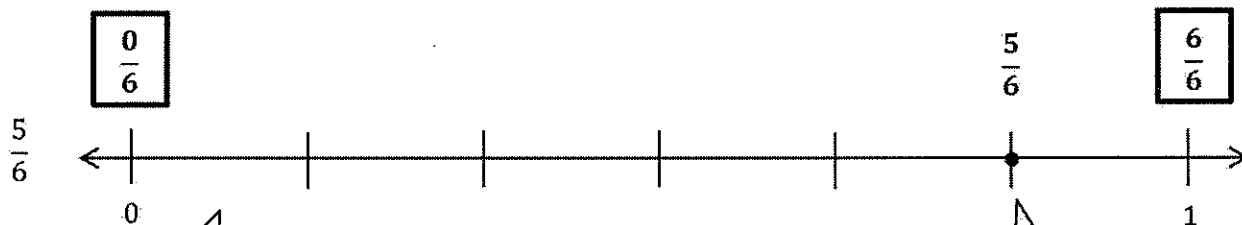

I know there are 6 equal parts in the whole, so I can estimate to partition this number line into 6 equal parts. Then, I can label the fractions at 0 and 1 as 0 sixths and 6 sixths.

I can count up to 5 sixths, starting at 1 sixth. I can touch and count, "1 sixth, 2 sixths, 3 sixths, 4 sixths, 5 sixths" and plot and label the fraction above the number line.

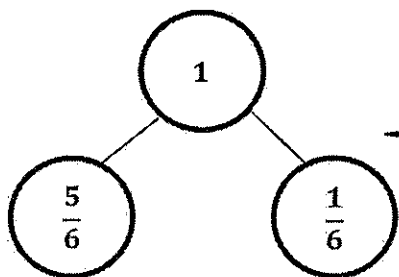

I can draw a 2-part number bond of 1 whole with 1 part labeled 5 sixths and the other part labeled 1 sixth. This number bond shows the fraction I plotted and the other part of the number line.

2. Claire made 6 equally spaced knots on her ribbon as shown.

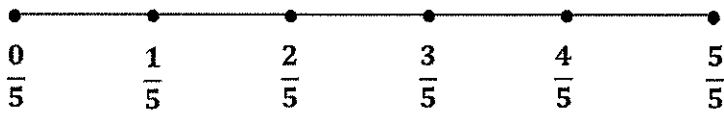

I know that I need to count the number of equal parts, not the number of knots Claire made. Even though Claire made 6 knots, there are 5 equal parts.

- a. Starting at the first knot and ending at the last knot, how many equal parts are formed by the 6 knots? Label each fraction at the knot.

*There are 5 equal parts.*

Since there are 5 equal parts, I can label the fractions as fifths, starting with 0 fifths at the first knot and 5 fifths at the last knot.

- b. What fraction of the rope is labeled at the fourth knot?

$\frac{3}{5}$

I know that the first knot is 0 fifths. When I touch and count by fifths to the fourth knot, I count 3 fifths.

## G3-M5-Lesson 16

1. Estimate to equally partition and label the fractions on the number line. Label the whole numbers as fractions, and box them.



In earlier practice, the left endpoint on the number line was 0. Here it starts at 1. The arrows on the number line tell me that there are more numbers, but it just doesn't show them. I can still partition the number line into fourths.

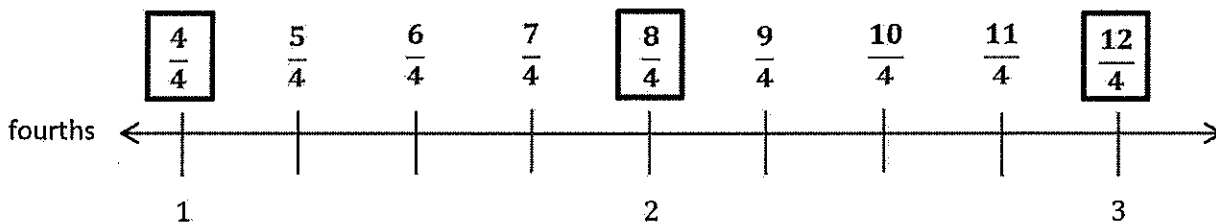

I know there are 4 fourths in 1, so I can label 4 fourths above the 1. Then, I can count on by fourths and label the fractions up to 3.

I see that 8 fourths is at the same point as 2. That means 8 fourths and 2 are equivalent. It's the same with 12 fourths and 3. I can box these numbers to show the whole numbers as fractions.

2. Draw a number line with endpoints 4 and 6. Label the whole numbers. Estimate to partition each interval into sixths, and label them. Box the fractions that are located at the same points as whole numbers.

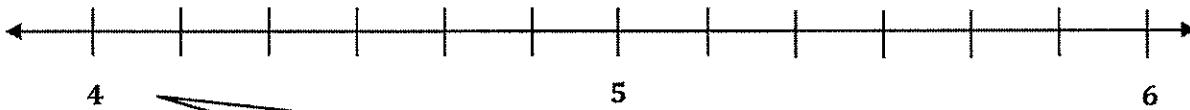

I can first draw a number line with the endpoints 4 and 6. I see that 5 is missing from the number line, so I need to mark and label 5 at the point halfway between 4 and 6. After labeling the whole numbers, I can partition each interval into 6 equal lengths.

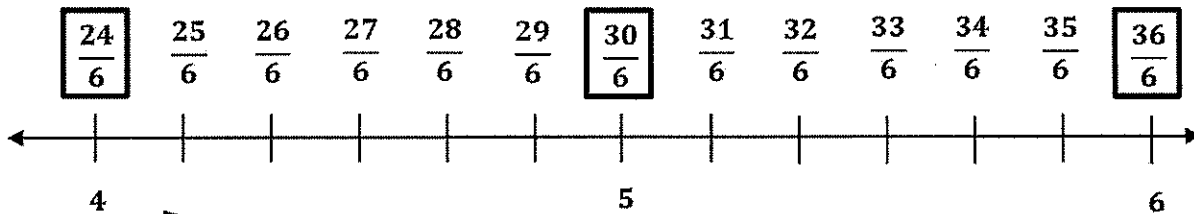

This number line starts at 4. I need to figure out how many sixths are equivalent to 4. I know 6 copies of 1 sixth make 1, so 12 copies of 1 sixth make 2, 18 copies make 3, and 24 copies make 4. I notice a pattern. I am skip-counting by 6 sixths to get to the next whole number. That means I can also just multiply  $4 \times 6$  sixths to get 24 sixths. Now that I know 24 sixths is equivalent to 4, I can count on to fill in the rest of my number line.

## G3-M5-Lesson 17

1. Locate and label the following fractions on the number line.

$\frac{16}{3}$

$\frac{20}{3}$

$\frac{12}{3}$

$\frac{14}{3}$

$\frac{10}{3}$

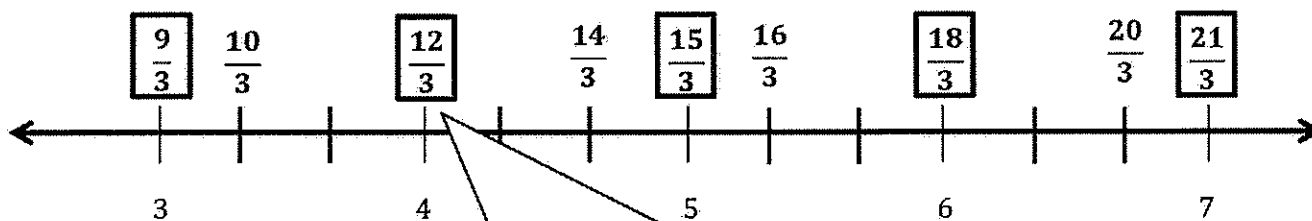

The number line begins with 3 because all of the given fractions are greater than 3.

The fractions I have to find and label are out of order. To help me place them on the number line I can first label the whole numbers as thirds. I'll box them so it's easy to remember they represent whole numbers. I can count by threes to find each number of thirds:  $1 = 3$  thirds,  $2 = 6$  thirds,  $3 = 9$  thirds,  $4 = 12$  thirds,  $5 = 15$  thirds,  $6 = 18$  thirds,  $7 = 21$  thirds. Now it's easier to label all of the given fractions on the number line.

I notice that all of these fractions are thirds. That means I need to partition my number line into thirds.

2. Students measure the lengths of their earthworms in science class. Nathan's measures 3 inches long. Elisha's is  $\frac{15}{4}$  inches long. Whose earthworm is longer? Draw a number line to help prove your answer.

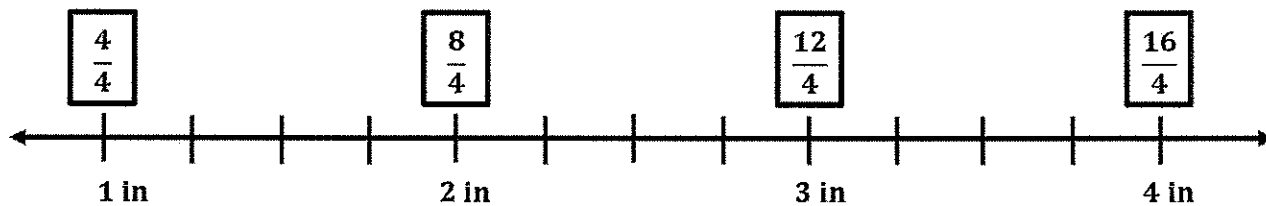

I know Elisha's earthworm is measured in fourths, so I need to partition my number line into fourths.

I know that both measurements are greater than 1 inch. I can use that information to choose where to start my number line.

I can label the whole numbers with their equivalent fractions by counting by fours.

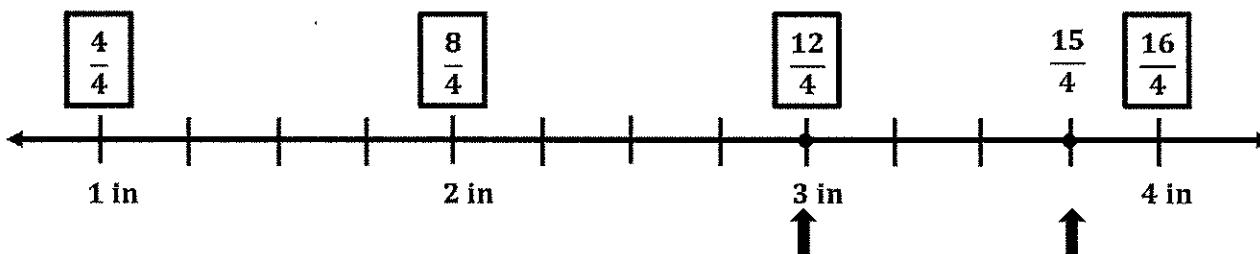

Length of Nathan's earthworm

Length of Elisha's earthworm

Now I can plot and label Nathan's and Elisha's measurements on the number line to compare whose earthworm is longer.

*Elisha's earthworm is longer. I can see that 3 inches, or  $\frac{12}{4}$ , comes before  $\frac{15}{4}$  inches on the number line.*

### G3-M5-Lesson 18

Place the two fractions on the number line. Circle the fraction with the distance closest to 0. Then, compare using  $>$ ,  $<$ , or  $=$ .

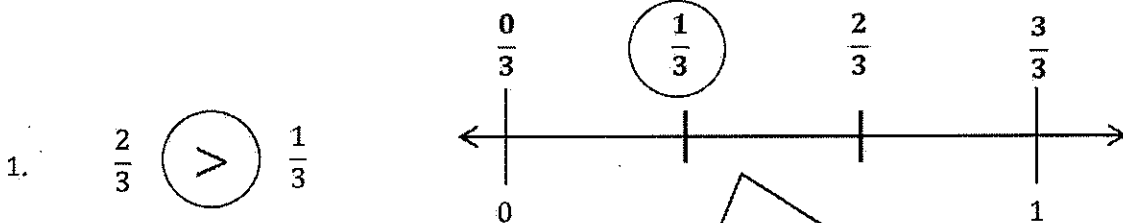

Both fractions are thirds, so I need to partition my number line into thirds. Then, I can count and label the 2 fractions on the number line and circle the fraction with the distance closest to 0.

I can think of the number line like a giant ruler. When I use a ruler, I start at 0 to measure. Then, I can compare the measurements. It's the same when comparing fractions. The fraction's distance from 0 helps me to compare. 1 third is a shorter distance from 0, so it is the smaller fraction. 2 thirds is a greater distance away from 0, so it is the larger fraction.

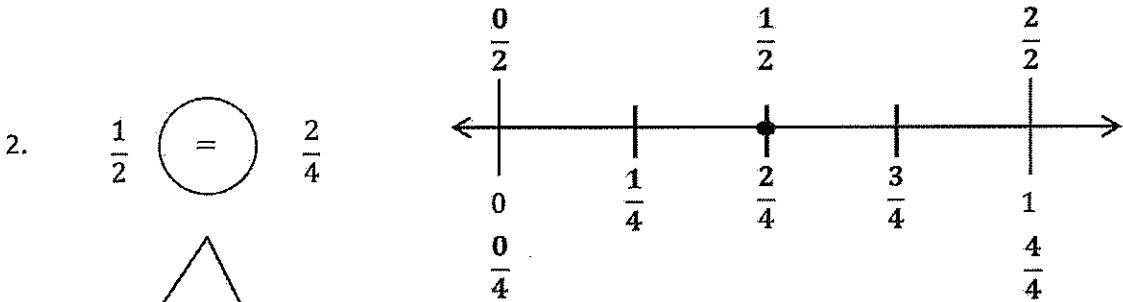

These fractions have different numbers on the bottom. I'll count and label halves above my number line and fourths below.

I know these are equivalent fractions because they are the same distance from 0 on the number line. I plotted them at the same point.

3. To get to the library, John walks  $\frac{1}{3}$  mile from his house. Susan walks  $\frac{3}{4}$  mile from her house. Draw a number line to model how far each student walks. Who walks farther? Explain how you know using pictures, numbers, and words.

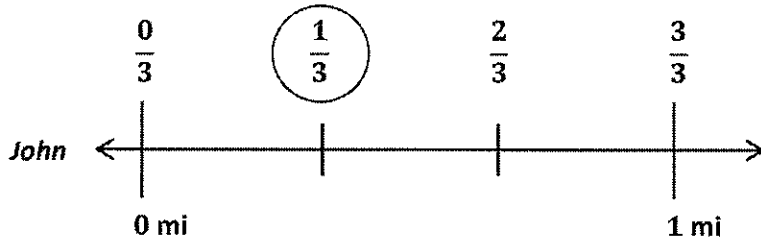

$$\frac{1}{3} < \frac{3}{4}$$

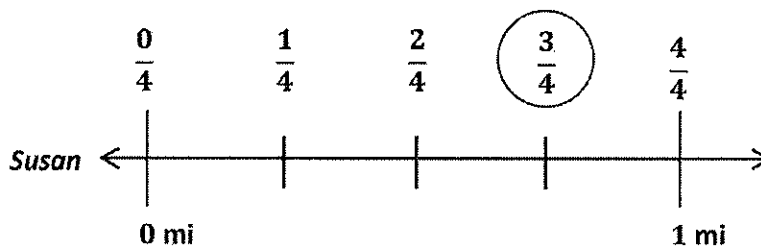

Susan walks farther. My number lines show that  $\frac{1}{3}$  is closer to 0 than  $\frac{3}{4}$ , so  $\frac{1}{3}$  is less than  $\frac{3}{4}$ .

I can draw 2 number lines. John's number line is partitioned into thirds, and Susan's number line is partitioned into fourths. I have to make sure that both my number lines have the same distance from 0 to 1 because if the whole changes, then the distance between the fractions also changes. I wouldn't be able to compare the 2 distances accurately.



## G3-M5-Lesson 19

1. Divide the number line into the given fractional unit. Then, label the fractions. Write each whole number as a fraction using the given unit.

Fifths

$$\frac{3}{5} \quad \frac{14}{5} \quad \frac{8}{5}$$

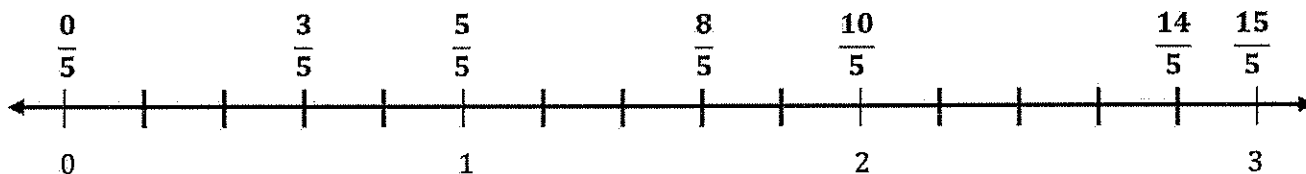

2. Use the number line above to compare the following using  $>$ ,  $<$ , or  $=$ .

I can compare these numbers by looking at their distance from 0. I know that the smaller number will be to the left of the larger number because that's closer to 0.

$$\frac{3}{5} < \frac{8}{5}$$

$$\frac{7}{5} < 2$$

$$3 > \frac{14}{5}$$

3 fifths is a shorter distance from 0, so it is a smaller fraction. 8 fifths is a greater distance from 0, so it is a larger fraction.

Writing each whole number as a fraction on the number line helps me compare whole numbers and fractions.

3. Use the number line from Problem 1 to help you. Which is larger: 2 or  $\frac{9}{5}$ ? Use words, pictures, and numbers to explain your answer.

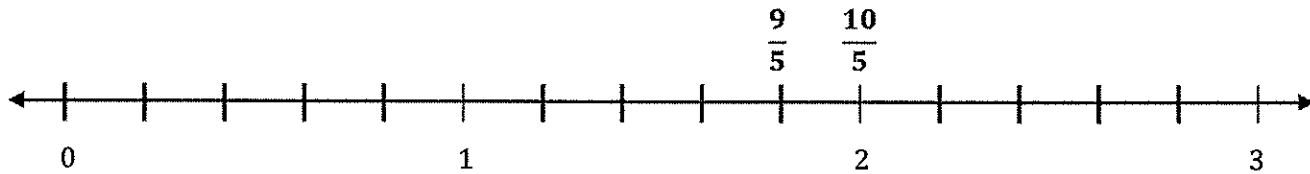

*2 is larger than  $\frac{9}{5}$ . We can see that  $\frac{9}{5}$  is to the left of 2 on the number line, which means that  $\frac{9}{5}$  is closer to 0, so  $\frac{9}{5}$  is less than 2.*

G3-M5-Lesson 20

1. These two shapes both show  $\frac{3}{4}$  shaded.

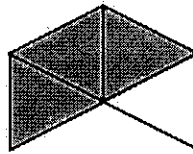
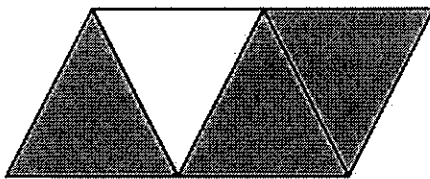

I can see that both shapes are made up of triangles, but the size of the triangles is different in each shape.

- a. Are the shaded areas equivalent? Why or why not?

*No, the shaded areas are not equivalent. Both shapes have 3 shaded triangles, but the size of the triangles in each shape is different. That means that the shaded areas can't be equivalent.*

- b. Draw two different representations of  $\frac{3}{4}$  that are equivalent.

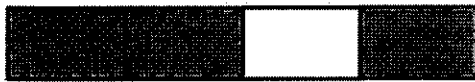
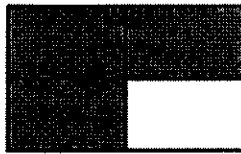

I can use the same units to draw two different representations of  $\frac{3}{4}$  that are equivalent. I can rearrange the units to make a different shape.

2. Brian walked  $\frac{2}{4}$  mile down the street. Wilson walked  $\frac{2}{4}$  mile around the block. Who walked more? Explain your thinking.

Brian

Wilson

I can see that these shapes are different, but I need to think about the units. They both walked  $\frac{2}{4}$  mile, and since the units (miles) and the fractions are the same, the fractions are equivalent.

*They both walked the same amount because the units are the same. They both walked  $\frac{2}{4}$  mile even though they walked in different ways. Brian walked in a straight line, and Wilson walked in a rectangular shape. The shapes look different, but they are both the same distance,  $\frac{2}{4}$  mile.*

### G3-M5-Lesson 21

1. Use the fractional units on the left to count up on the number line. Label the missing fractions on the blanks.

I can count by halves to help me label the number line. 0 halves, 1 half, 2 halves, 3 halves, 4 halves. I can do the same thing with eighths.

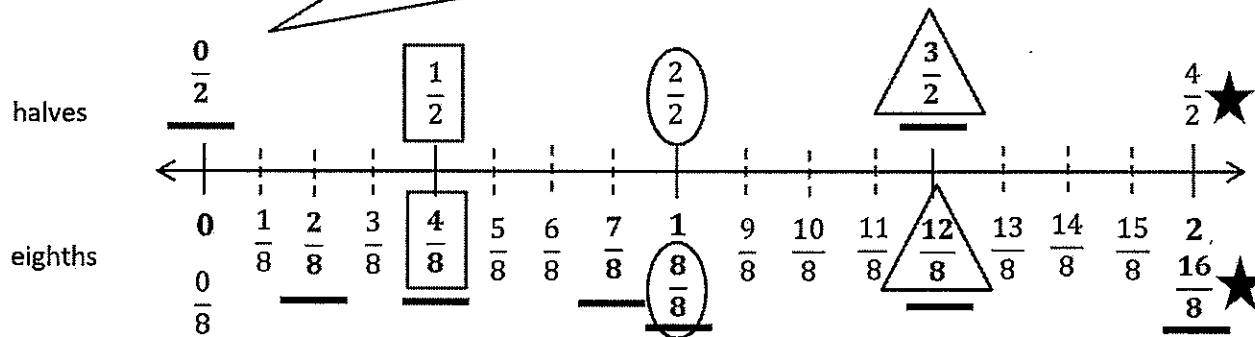

2. Use the number line above to do the following:

- Circle fractions equal to 1.
- Draw a box around fractions equal to 1 half.
- Draw a star next to fractions equal to 2.
- Draw a triangle around fractions equal to 3 halves.
- Write a pair of fractions that are equivalent.

I know that equivalent fractions are at the same point on the number line. I can see that  $\frac{2}{2}$  and  $\frac{8}{8}$  are equal to 1 because they are at the same point on the number line.

$\frac{3}{2}$  and  $\frac{12}{8}$  are equivalent fractions because they are at the same point on the number line.

$$\underline{\frac{3}{2}} = \underline{\frac{12}{8}}$$

### G3-M5-Lesson 22

1. Write the shaded fraction of each figure on the blank. Then, draw a line to match the equivalent fractions.

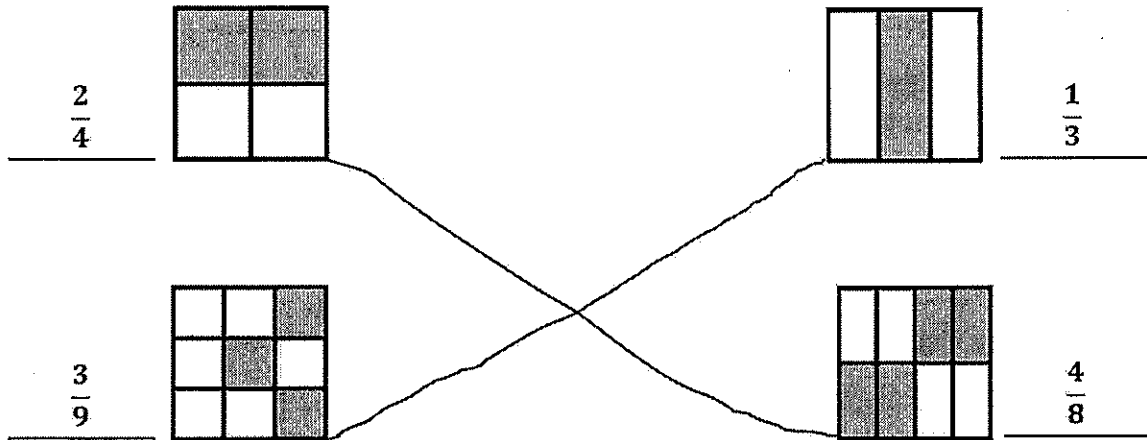

I can imagine the 2 shaded parts in this column moved to the center column, which makes it easy for me to see that  $\frac{1}{3}$  and  $\frac{3}{9}$  are equivalent.

I can imagine the 2 shaded parts in this row moved to the top row, which makes it easy for me to see that  $\frac{2}{4}$  and  $\frac{4}{8}$  are equivalent.

2. Complete the fraction to make a true statement.

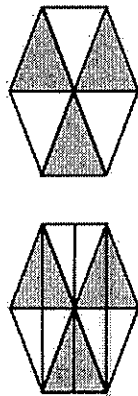

$$\frac{3}{6} = \frac{6}{12}$$

I can count the shaded parts in the second shape to see that  $\frac{3}{6}$  and  $\frac{6}{12}$  are equivalent.

3. Why does it take 2 copies of  $\frac{1}{4}$  to show the same amount as 1 copy of  $\frac{1}{2}$ ? Explain your answer in words and pictures.

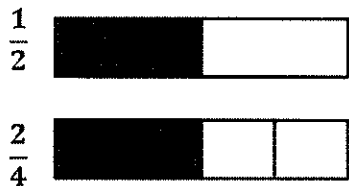

I can draw 2 models, where each whole is the same size. Then, I can partition and shade to show that  $\frac{2}{4} = \frac{1}{2}$ .

*There is double the number of equal parts in fourths than halves, so you need double the number of copies to show equivalent fractions.*

4. How many eighths does it take to make the same amount as  $\frac{1}{4}$ ? Explain your answer in words and pictures.

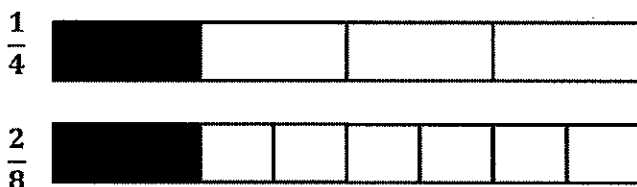

My models show that for every  $\frac{1}{4}$ , there are  $\frac{2}{8}$ . Eighths are smaller units than fourths, so it takes more eighths to equal  $\frac{1}{4}$ .

*It takes 2 eighths to make the same amount as  $\frac{1}{4}$  because there is double the number of equal parts in eighths, so it takes double the number of copies.*

5. A pizza was cut into 6 equal slices. If Lizzie ate  $\frac{1}{3}$  of the pizza, how many slices did she eat? Explain your answer using a number line and words.

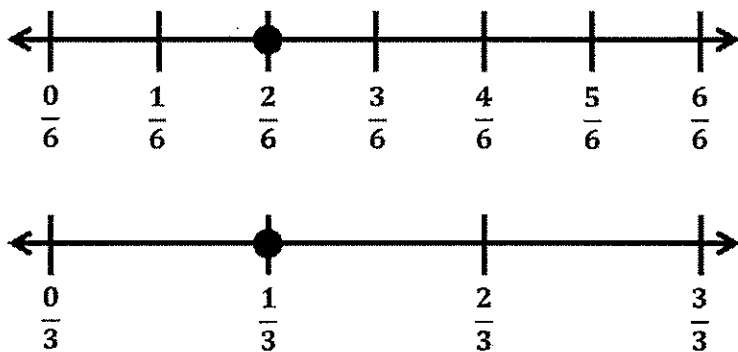

I can draw two number lines that are the same size. I can partition one into sixths and the other into thirds. My number lines show that  $\frac{1}{3}$  is equivalent to  $\frac{2}{6}$ . I also could have drawn one number line and partition it into thirds and sixths.

*Lizzie ate 2 slices of pizza because my number lines show that  $\frac{1}{3} = \frac{2}{6}$  and  $\frac{2}{6}$  means that she ate 2 of the 6 pieces.*

G3-M5-Lesson 23

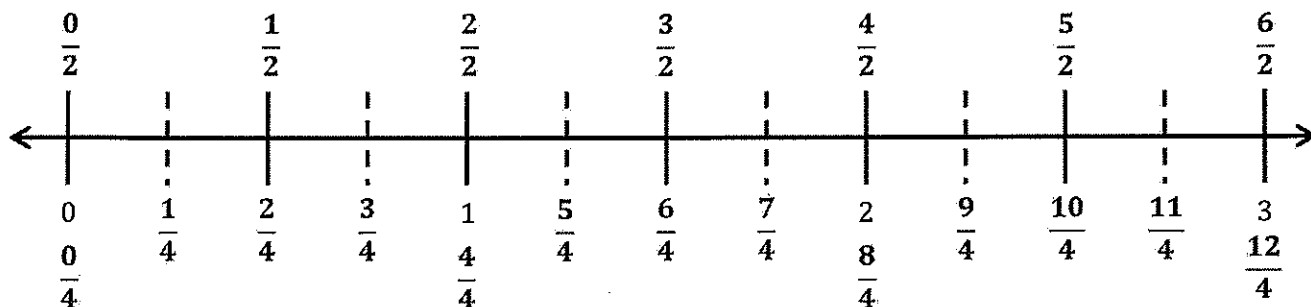

1. On the number line above, divide each whole into halves, and label the halves above the line.
2. On the number line above, divide each whole into fourths, and label the fourths below the line.
3. Write the fractions that name the same place on the number line.

$$\frac{0}{4} = \frac{0}{2}$$

$$\frac{2}{4} = \frac{1}{2}$$

$$\frac{4}{4} = \frac{2}{2}$$

$$\frac{6}{4} = \frac{3}{2}$$

$$\frac{8}{4} = \frac{4}{2}$$

$$\frac{10}{4} = \frac{5}{2}$$

$$\frac{12}{4} = \frac{6}{2}$$

I can use an equal sign to show that these are equivalent because they are at the same point on the number line.

4. Use your number line to help you name the fractions equivalent to  $\frac{14}{4}$  and  $\frac{8}{2}$ . Draw the part of the number line that would include these fractions below, and label it.

$$\frac{14}{4} = \frac{7}{2}$$

$$\frac{8}{2} = \frac{16}{4}$$

I know these fractions are equivalent because they are at the same point on the number line.

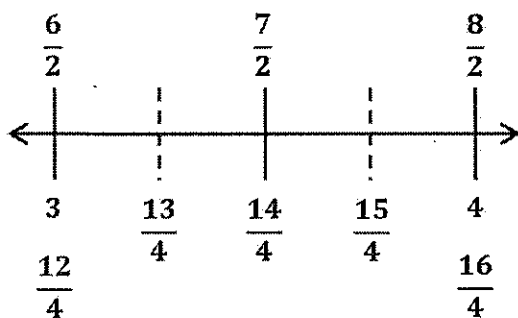

I can use my number line to count on by halves to  $\frac{8}{2}$ , which is the same as 4. I can draw a number line showing the interval of 3 to 4 and partition and label the halves and fourths.

5. Write two different fraction names for the dot on the number line. You may use halves, fourths, or eighths.

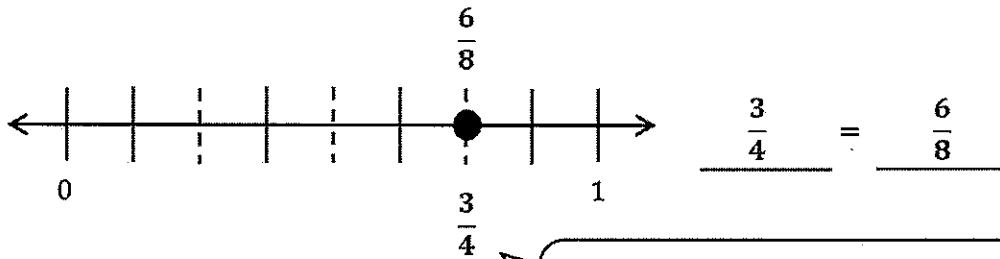

I can partition the interval into eighths. Then, I can count by fourths and eighths to label the dot on the number line.

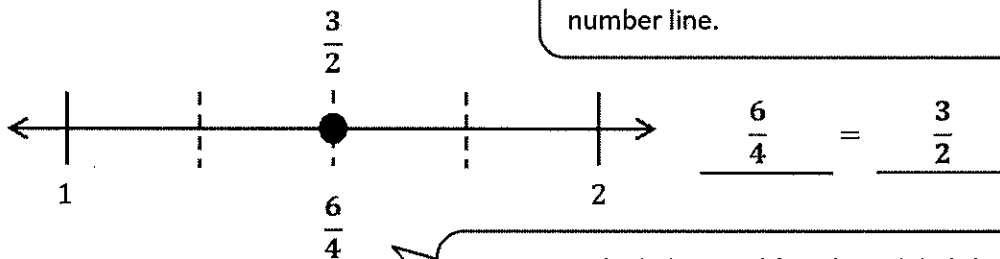

I can count by halves and fourths to label the dot on the number line. I can start counting at  $\frac{2}{2}$  and  $\frac{4}{4}$  because the interval starts at 1, not 0.

6. Megan and Hunter bake two equal-sized pans of brownies. Megan cuts her pan of brownies into fourths, and Hunter cuts his pan of brownies into eighths. Megan eats  $\frac{1}{4}$  of her pan of brownies. If Hunter wants to eat the same amount of brownies as Megan, how many of his brownies will he have to eat? Write the answer as a fraction. Draw a number line to explain your answer.

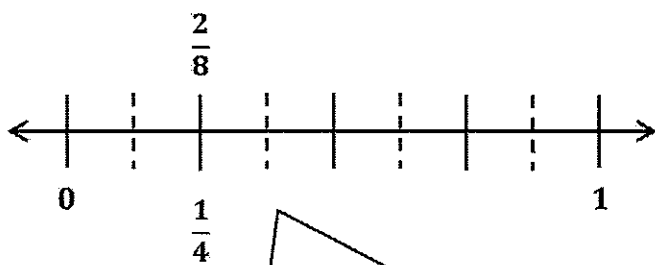

I can draw a number line and partition it into fourths and eighths. I can count by fourths to find and label the point  $\frac{1}{4}$ . I can count by eighths to find and label the point that is equivalent to  $\frac{1}{4}$ .

The fractions  $\frac{1}{4}$  and  $\frac{2}{8}$  are at the same point on the number line, so they are equivalent.

Hunter needs to eat  $\frac{2}{8}$  of his brownies to eat the same amount as Megan because  $\frac{2}{8} = \frac{1}{4}$ .



## G3-M5-Lesson 24

1. Complete the number bond as indicated by the fractional unit. Partition the number line into the given fractional unit, and label the fractions. Rename 0 and 1 as fractions of the given unit.

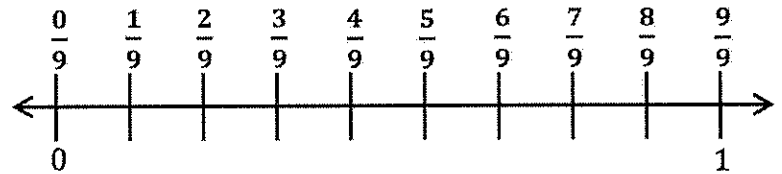
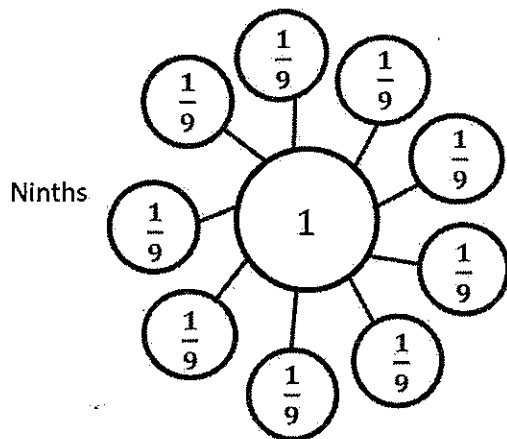

I can partition the number line into nine equal parts and count by ninths to label the fractions.

The fractional unit, ninths, tells me that I need to make nine parts on my number bond. Each part is  $\frac{1}{9}$  because 9 copies of  $\frac{1}{9}$  make a whole.

2. Mrs. Smith bakes two large apple pies. She cuts one pie into fourths and gives it to her daughter. She cuts the other pie into eighths and gives it to her son. Her son says, "My pie is bigger because it has more pieces than yours!" Is he correct? Use words, pictures, or a number line to help you explain.

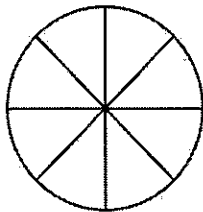

son's pie: eighths

**No, he is not correct. His pie has more pieces, but the pieces are smaller than his sister's pieces. Both pies are the same size so they both have the same amount of pie, even though they have a different number of pieces.**

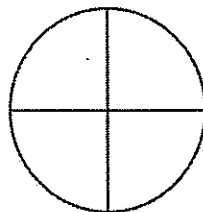

daughter's pie: fourths

I can draw two same-sized circles to represent the pies. I can partition the circles into eighths and fourths.

### G3-M5-Lesson 25

1. Label the following models as fractions inside the boxes.

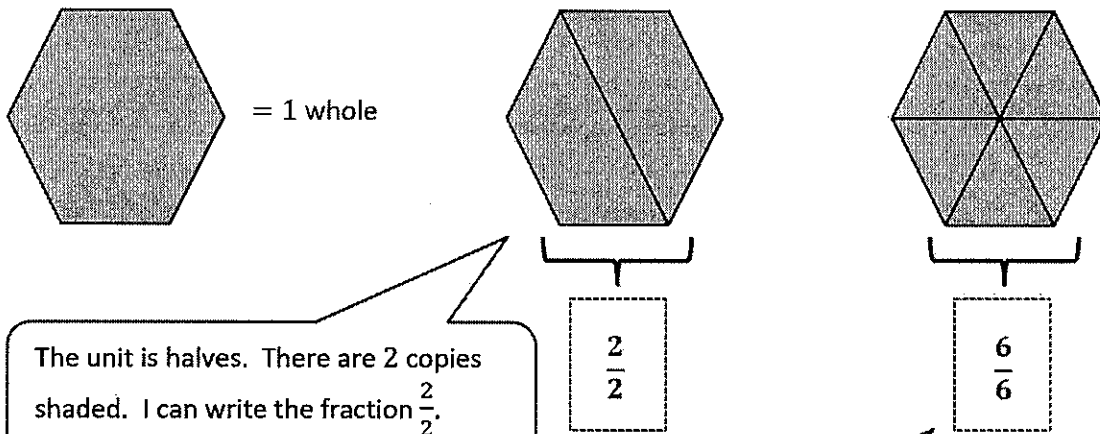

The unit is halves. There are 2 copies shaded. I can write the fraction  $\frac{2}{2}$ .

The unit is sixths. There are 6 copies shaded. I can write the fraction  $\frac{6}{6}$ .

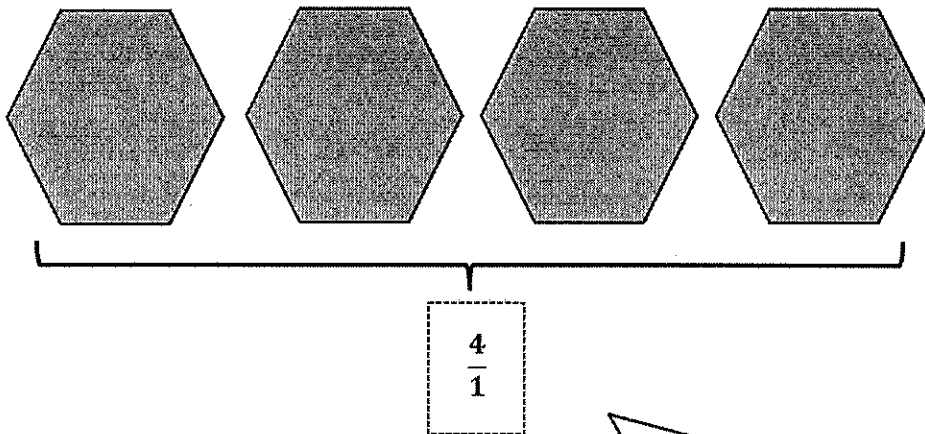

The unit is 1 whole. There are 4 copies shaded. I can write the fraction  $\frac{4}{1}$ .

2. Fill in the missing whole numbers in the boxes below the number line. Use the pattern to rename the whole numbers as fractions in the boxes above the number line.

I see a pattern in how whole numbers are written as fractions. I can use the whole numbers on the bottom to help me fill in the fractions on the top.  $10 = \frac{10}{1}$

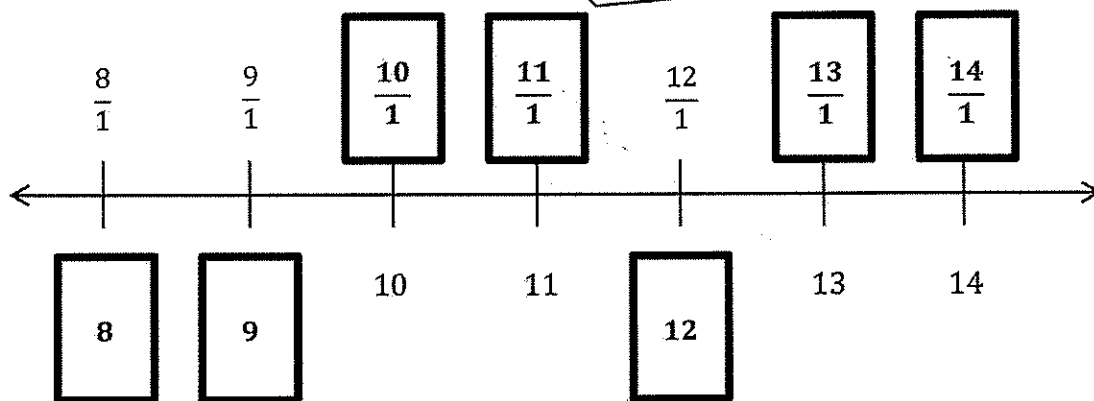

I can use the fractions on the top to help me fill in the whole numbers on the bottom.  $\frac{8}{1} = 8$

3. Explain the difference between these fractions with words and pictures.

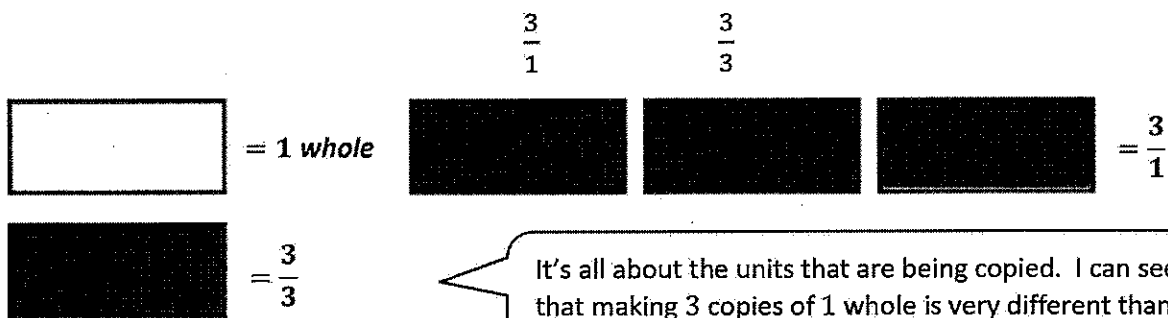

The fractions  $\frac{3}{1}$  and  $\frac{3}{3}$  are different because they both represent 3 copies, but the units that are copied are different. The fraction  $\frac{3}{1}$  is 3 copies of 1 whole, and the fraction  $\frac{3}{3}$  is 3 copies of 1 third. 3 copies of 1 whole, or  $\frac{3}{1}$ , is greater than 3 copies of 1 third, or  $\frac{3}{3}$ . My picture shows that  $\frac{3}{1}$  is 3 wholes, and  $\frac{3}{3}$  is only 1 whole.

### G3-M5-Lesson 26

1. Partition the number line to show the fractional units. Then, draw number bonds with copies of 1 whole for the circled whole numbers.

I can partition the whole number intervals into fourths. I can count by fourths to label the fractions. I need to start at  $\frac{8}{4}$  because this number line starts at 2.

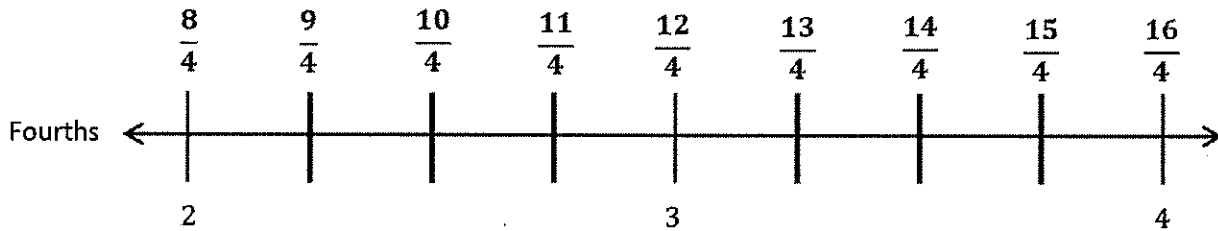

$2 = \underline{8}$  fourths

$3 = \underline{12}$  fourths

$4 = \underline{16}$  fourths

$2 = \frac{8}{4}$

$3 = \frac{12}{4}$

$4 = \frac{16}{4}$

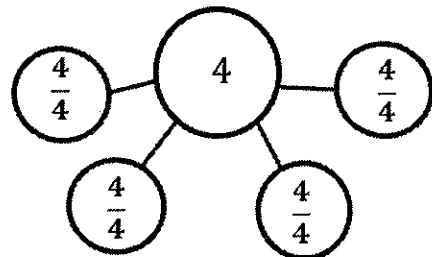
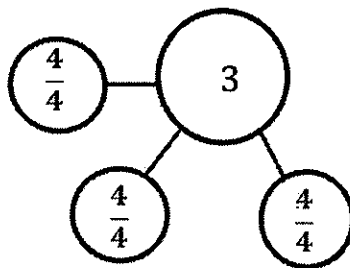
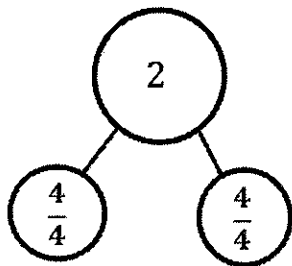

I can make copies of 1 whole to represent each whole number. Since the fractional unit is fourths, 1 whole can be represented by  $\frac{4}{4}$ . It takes 2 copies of  $\frac{4}{4}$  to make the whole number 2.

2. Use the number line to write the fractions that name the whole numbers for each fractional unit. The first one has been done for you.

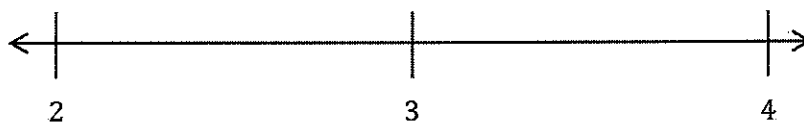

Thirds	$\frac{6}{3}$	$\frac{9}{3}$	$\frac{12}{3}$
Sixths	$\frac{12}{6}$	$\frac{18}{6}$	$\frac{24}{6}$
Ninths	$\frac{18}{9}$	$\frac{27}{9}$	$\frac{36}{9}$

I know that  $\frac{12}{6} = 2$ . I can count by sixths to find the other fractions that name the whole numbers on the number line. I can do the same thing for ninths.

3. Monica walks  $\frac{1}{4}$  of a mile on Monday. Each day after that, she walks  $\frac{1}{4}$  of a mile more than she did the day before. Draw and partition a number line to represent how far Monica walks on Monday, Tuesday, Wednesday, and Thursday. What fraction of a mile does she walk on Thursday?

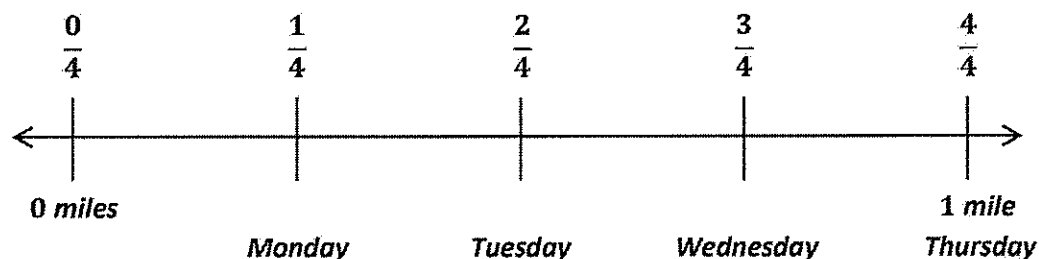

Monica walks  $\frac{4}{4}$  of a mile on Thursday.

I can draw a number line and partition it into fourths because the fractional unit is fourths and Monica walks for 4 days. I can see on my number line that on Thursday Monica walks  $\frac{4}{4}$  of a mile, which is the same as 1 mile.

### G3-M5-Lesson 27

1. Use the pictures to model equivalent fractions. Fill in the blanks, and answer the questions.

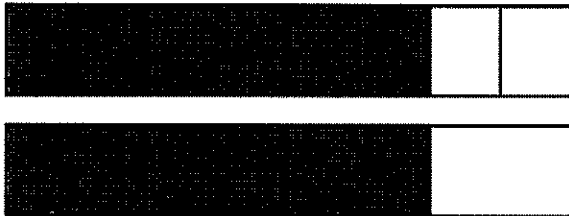

I can shade 6 eighths, and then I can shade fourths until the same amount in each model is shaded. It takes 3 fourths to equal 6 eighths.

6 eighths is equal to 3 fourths.

$$\frac{6}{8} = \frac{3}{4}$$

The whole stays the same.

What happens to the size of the equal parts when there are fewer equal parts?

**When there are fewer equal parts, the size of each equal part gets bigger. Fourths are bigger than eighths.**

2. Six friends share 2 crackers that are both the same size. The crackers are represented by the 2 rectangles below. The first cracker is cut into 3 equal parts, and the second is cut into 6 equal parts. How can the 6 friends share the crackers equally without breaking any of the pieces?

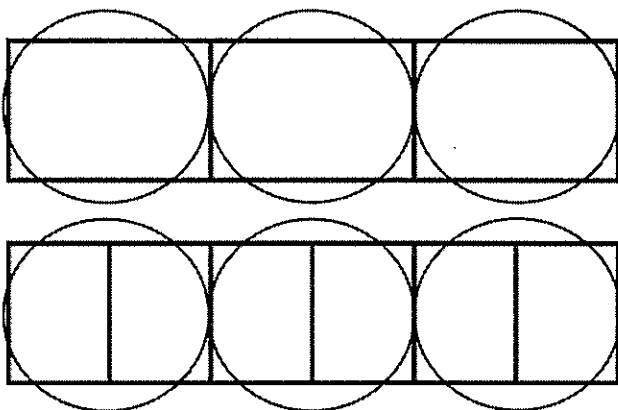

I can partition the first cracker into thirds and the second cracker into sixths. I can circle 6 equal amounts to show how much each friend gets.

Three friends each get  $\frac{1}{3}$  of the first cracker. The other 3 friends each get  $\frac{2}{6}$  of the second cracker.

They all get the same amount because  $\frac{1}{3} = \frac{2}{6}$ .

3. Mrs. Mills cuts a pizza into 6 equal slices. Then, she cuts every slice in half. How many of the smaller slices does she have? Use words and numbers to explain your answer.

*She has 12 smaller slices of pizza. Since she cut each slice in half, that means that she doubled the number of pieces and  $6 \times 2 = 12$ . The smaller the pieces, the more pieces it takes to make a whole.*

If I need to, I can draw a picture. I can draw a circle and partition it into sixths. Then, I can partition each sixth into 2 equal pieces. That would make 12 pieces.

## G3-M5-Lesson 28

1. Shade the models to compare the fractions.

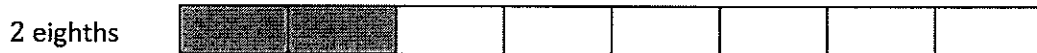

Which is larger, 2 fourths or 2 eighths? Why? Use words to explain.

*2 fourths is larger than 2 eighths because the more times you cut the whole, the smaller the pieces get. The number of pieces I shaded is the same, but the sizes of the pieces are different. Eighths are much smaller than fourths.*

2. After baseball practice, Steven and Eric each buy a 1-liter bottle of water. Steven drinks 3 sixths of his water. Eric drinks 3 fourths of his water. Who drinks more water? Draw a picture to support your answer.



*Eric drinks more water.*

I can see from my picture that 3 fourths is greater than 3 sixths. I shaded the same number of parts, but the wholes are partitioned into different fractional units. Sixths are smaller than fourths.

Steven and Eric each buy a 1-liter bottle of water, so I need to draw my 2 wholes exactly the same size. If the size of the whole changes, I won't be able to accurately compare the 2 fractions.



### G3-M5-Lesson 29

1. Draw your own model to compare the following fractions. Then, complete the number sentence by writing  $>$ ,  $<$ , or  $=$ .

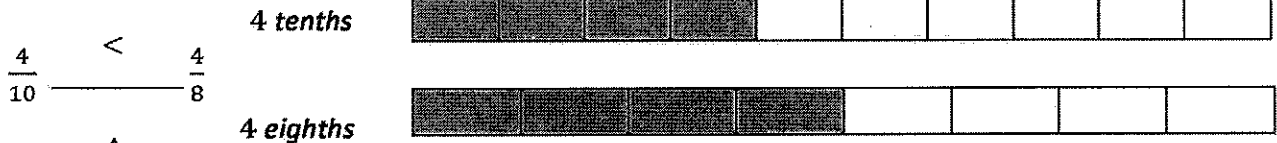

I can read this number sentence as, "4 tenths is less than 4 eighths."

When comparing fractions, it is important to draw wholes that are the same size.

2. Draw 2 number lines with endpoints 0 and 1 to show each fraction in Problem 1. Use the number lines to explain how you know your comparison in Problem 1 is correct.

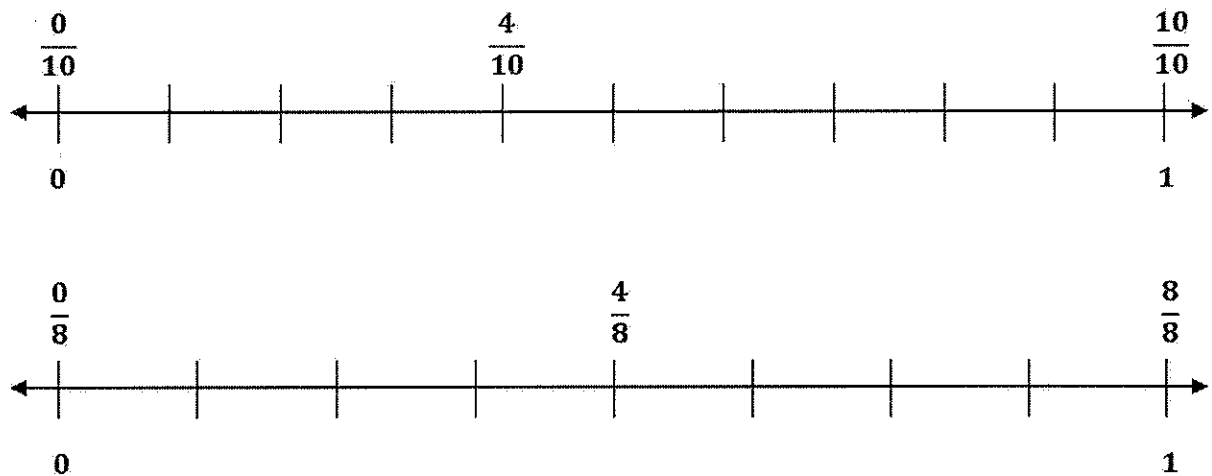

My answer in Problem 1 is correct. 4 tenths is less than 4 eighths because 4 tenths is a shorter distance from 0 than 4 eighths on the number line.

I can see that 10 tenths and 8 eighths are equivalent fractions because they have the same point on the number line. This is also true for 0 tenths and 0 eighths.

## G3-M5-Lesson 30

Theodore precisely partitions his red strip into fifths using the number line method below. Describe step by step how Theodore partitions his strip into equal units using only a piece of notebook paper and a straight edge.

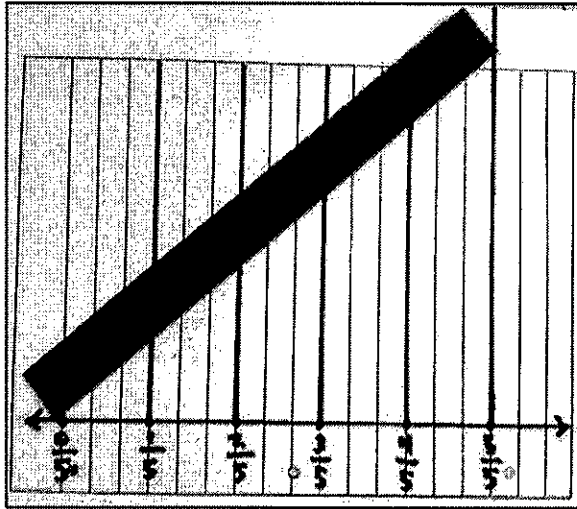

First, Theodore uses the paper's margin line to draw a number line. He then labels fifths on his number line from 0 to 1. He uses 3 spaces for each fifth. Next, at each fifth, he draws vertical lines up from the number line to the top of the paper. He then takes his red strip and angles it so that the left end touches the 0 endpoint on the number line, and the right end touches the line at 5 fifths, or 1. Finally, he marks on the red strip where the vertical points touch it. This creates equal units on the red strip. Theodore can double check by measuring them with a ruler.

Using this method, I can make fractional units precisely without a ruler. If I want to partition longer strips, like a meter strip, I tape more lined papers above the first one so that I can make a sharper angle with the longer strip.