

Homework Helpers

Grade 4 Module 3

G4-M3-Lesson 1

1. Determine the perimeter and area of rectangles A and B.

To find the area of rectangle A, I can skip count the square units inside: 5, 10, 15, 20, 25. Or I can multiply: $5 \times 5 = 25$.

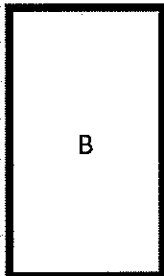
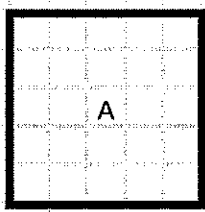

I can't see the units inside rectangle B. So, I count the number of units for the side lengths and use the formula for area ($A = l \times w$).

a. $A =$ 25 square units $A =$ 28 square units

b. $P =$ 20 units $P =$ 22 units

I can use a formula for perimeter such as $P = 2 \times (l + w)$, $P = l + w + l + w$, or $P = 2l + 2w$.

2. Given the rectangle's area, find the unknown side length.

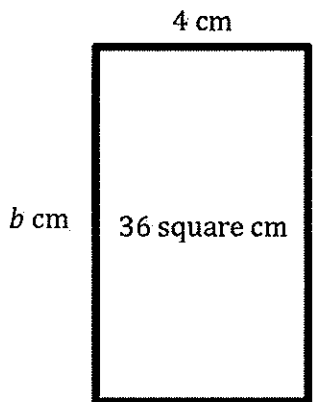

I can think, "4 times what number equals 36?" Or, I can divide to find the unknown side length: $A \div l = w$.

$$A = l \times w$$

$$36 = 4 \times b$$

$$b = 9$$

$$b = \underline{\quad 9 \quad}$$

The unknown side length of the rectangle is 9 centimeters.

3. The perimeter of this rectangle is 250 centimeters. Find the unknown side length of this rectangle.

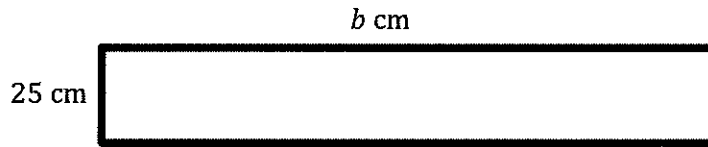

$$P = w + w + l + l$$

$$250 = 25 + 25 + l + l$$

$$250 = 50 + l + l$$

$$250 - 50 = 200$$

$$200 \div 2 = b$$

$$100 = b$$

I subtract to find the sum of the unknown sides.
I divide to find the unknown length, b cm.

The length of the rectangle is 100 cm.

4. The following rectangle has whole number side lengths. Given the area and perimeter, find the length and width.

$$A = 48 \text{ square cm}$$

$$P = 32 \text{ cm}$$

$$l = \underline{12 \text{ cm}}$$



$$w = \underline{4 \text{ cm}}$$

I list factor pairs for 48.

*Dimensions of a
48 square cm Rectangle*

Width	Length
1 cm	48 cm
2 cm	24 cm
3 cm	16 cm
4 cm	12 cm
6 cm	8 cm

I try the different possible factors as side lengths as I solve for a perimeter of 32 cm using the formula $P = 2L + 2W$.

$$P = (2 \times 8) + (2 \times 6)$$

$$P = 16 + 12$$

$$P = 28$$

No!

$$P = (2 \times 12) + (2 \times 4)$$

$$P = 24 + 8$$

$$P = 32$$

Yes! The factors 4 and 12 work!

G4-M3-Lesson 2

1. A rectangular pool is 2 feet wide. It is 4 times as long as it is wide.

- a. Label the diagram with the dimensions of the pool.

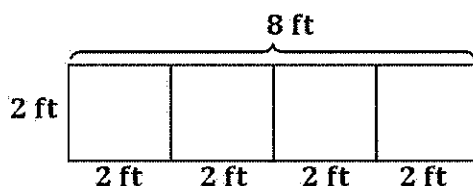

- b. Find the perimeter of the pool.

$$P = 2 \times (l + w)$$

$$P = 2 \times (8 + 2)$$

$$P = 2 \times 10$$

$$P = 20$$

I choose one of the 3 formulas I learned in Lesson 1 to solve for perimeter.

The perimeter of the pool is 20 ft.

2. The area of Brette's bedroom rug is 6 square feet. The longer side measures 3 feet. Her living room rug is twice as long and twice as wide as the bedroom rug.

- a. Draw and label a diagram of Brette's bedroom rug. What is its perimeter?

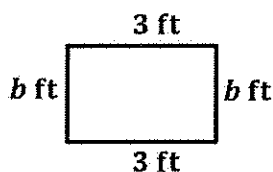

$$A = l \times w$$

$$6 = 3 \times w$$

$$b = 6 \div 3$$

$$b = 2$$

I divide to find the width.

$$P = 2l + 2w$$

$$P = (2 \times 3) + (2 \times 2)$$

$$P = 6 + 4$$

$$P = 10$$

The perimeter of Brette's bedroom rug is 10 ft.

- b. Draw and label a diagram of Brette's living room rug. What is its perimeter?

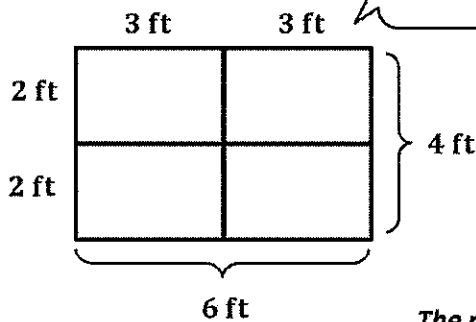

I draw a diagram of Brette's bedroom rug. Then I double the length and the width to model the living room rug.

$$P = 2l + 2w$$

$$P = (2 \times 6) + (2 \times 4)$$

$$P = 12 + 8$$

$$P = 20$$

The perimeter of the living room rug is 20 ft.

- c. What is the relationship between the two perimeters?

Sample Answer: The perimeter of the bedroom rug is 10 ft. The perimeter of the living room rug is 20 ft. The living room rug is double the perimeter of the bedroom rug. I know because $2 \times 10 = 20$.

I explain a pattern I notice. I verify my thinking with an equation.

- d. Find the area of the living room rug using the formula $A = l \times w$.

$$A = l \times w$$

The area of the living room rug is 24 square feet.

$$A = 6 \times 4$$

$$A = 24$$

- e. The living room rug has an area that is how many times that of the bedroom rug?

Sample Answer: The area of the bedroom rug is 6 square feet. The area of the living room rug is 24 square feet. 4 times 6 is 24. The area of the living room rug is 4 times the area of the bedroom rug.

- f. Compare how the perimeter changed with how the area changed between the two rugs. Explain what you notice using words, pictures, or numbers.

Sample Answer: The perimeter of the living room rug is 2 times the perimeter of the bedroom rug. But, the area of the living room rug is 4 times the area of the bedroom rug! I notice that when we double each of the side lengths, the perimeter doubles, and the area quadruples.

G4-M3-Lesson 3

Solve the following problems. Use pictures, numbers, or words to show your work.

1. A calendar is 2 times as long and 3 times as wide as a business card. The business card is 2 inches long and 1 inch wide. What is the perimeter of the calendar?

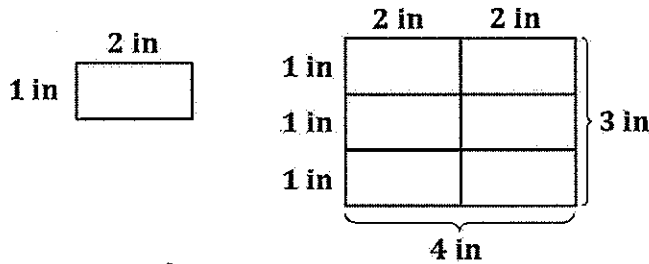

$$P = 2 \times (l + w)$$

$$P = 2 \times (4 \text{ in} + 3 \text{ in})$$

$$P = 2 \times 7 \text{ in}$$

$$P = 14 \text{ in}$$

The perimeter of the calendar is 14 inches.

I draw a diagram with a width 3 times that of the card (3 in).
I label the length to equal twice the width of the card (4 in).

2. Rectangle A has an area of 64 square centimeters. Rectangle A is 8 times as many square centimeters as rectangle B. If rectangle B is 4 centimeters wide, what is the length of rectangle B?

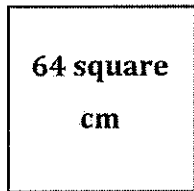

Rectangle A

$$1 \text{ unit} = B \text{ square cm}$$

$$8 \text{ units} = 64 \text{ square cm}$$

$$64 \div 8 = B$$

$$B = 8$$

There are so many ways to solve!

The area of rectangle B is 8 square centimeters.

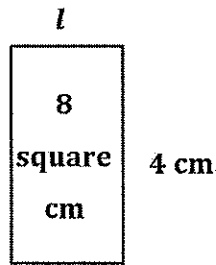

Rectangle B

$$A = w \times l$$

$$8 = 4 \times l$$

$$l = 8 \div 4$$

$$l = 2$$

The length of rectangle B is 2 cm.

G4-M3-Lesson 4

1. Fill in the blanks in the following equations.

a. 100 $\times 7 = 700$

b. $4 \times$ 1,000 $= 4,000$

c. 50 $= 10 \times 5$

I ask myself, "How many sevens are equal to 700?"

I use unit form to solve. If I name the units, multiplying large numbers is easy! I know $4 \div 4 = 1$, so 4 thousands $\div 4$ is 1 thousand.

Draw place value disks and arrows to represent each product.

2. $15 \times 100 =$ 1,500

$15 \times 10 \times 10 =$ 1,500

$(1 \text{ ten } 5 \text{ ones}) \times 100 =$ 1 thousand 5 hundreds

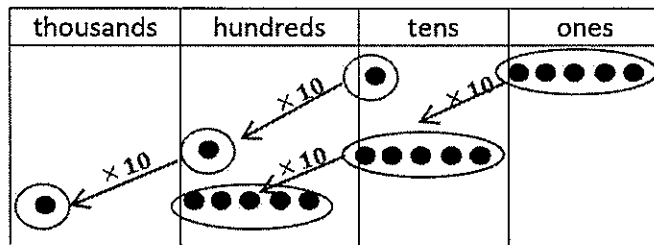

Fifteen is 1 ten 5 ones. I draw an arrow to show times 10 for the 1 ten and also for the 5 ones. I multiply by 10 again and I have 1 thousand 5 hundreds.

If I shift a digit one place to the left on the chart, that digit becomes 10 times as much as its value to the right.

Decompose each multiple of 10, 100, or 1,000 before multiplying.

3. $2 \times 300 = 2 \times$ 3 \times 100
 $=$ 6 \times 100
 $=$ 600

4. $6 \times 7,000 =$ 6 \times 7 \times 1,000
 $=$ 42 \times 1,000
 $=$ 42,000

I can decompose 300 to make an easy fact to solve!
 I know 2×3 hundreds $= 6$ hundreds.

G4-M3-Lesson 5

1. $2 \times 4,000 = \underline{8,000}$
2 times 4 thousands is 8 thousands.

I draw 2 groups of 4 thousands and circle each group. I see a pattern! 2 groups of 4 units is 8 units.

thousands	hundreds	tens	ones
●●●●			
●●●●			

$$\begin{array}{r} 4,000 \\ \times \quad 2 \\ \hline 8,000 \end{array}$$

$2 \times 4 \text{ thousands} = 8 \text{ thousands}$

Writing the equation in unit form helps me when one of the factors is a multiple of 10.

2. Find the product.

a. $4 \times 70 = 280$ $4 \times 7 \text{ tens} = 28 \text{ tens}$	b. $4 \times 60 = 240$ $4 \times 6 \text{ tens} = 24 \text{ tens}$	c. $4 \times 500 = 2,000$ $4 \times 5 \text{ hundreds} = 20 \text{ hundreds}$	d. $6,000 \times 5 = 30,000$ $6 \text{ thousands} \times 5 = 30 \text{ thousands}$
---	---	--	---

3. At the school cafeteria, each student who orders lunch gets 7 chicken nuggets. The cafeteria staff prepares enough for 400 kids. How many chicken nuggets does the cafeteria staff prepare altogether?

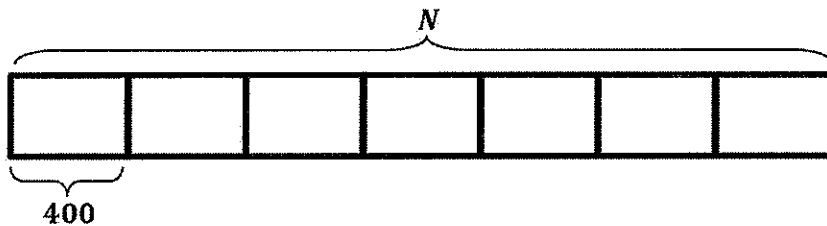

$$\begin{aligned} N &= 7 \times 400 \\ N &= 7 \times (4 \times 100) \\ N &= (7 \times 4) \times 100 \\ N &= 28 \times 100 \\ N &= 2,800 \end{aligned}$$

The staff prepares 2,800 chicken nuggets.

I can decompose 400 into 4×100 to unveil an easy fact (7×4). Or I can use unit form to solve. 7 times 4 hundreds is 28 hundreds.

G4-M3-Lesson 6

Represent the following problem by drawing disks in the place value chart.

1. To solve 30×40 , think:

$(3 \text{ tens} \times 4) \times 10 = \underline{1,200}$

$30 \times (4 \times 10) = \underline{1,200}$

$30 \times 40 = \underline{1,200}$

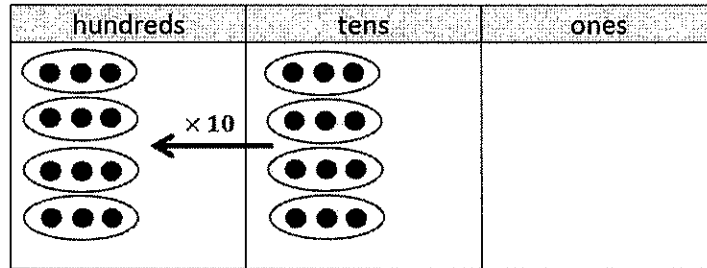

I draw 4 groups of 3 tens multiplied by 10.

2. Draw an area model to represent 30×40 .

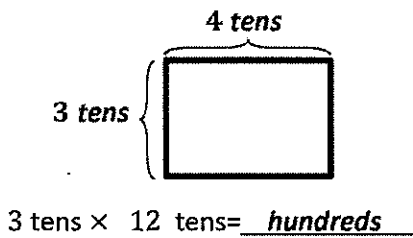

When I multiply tens by tens, I get hundreds.

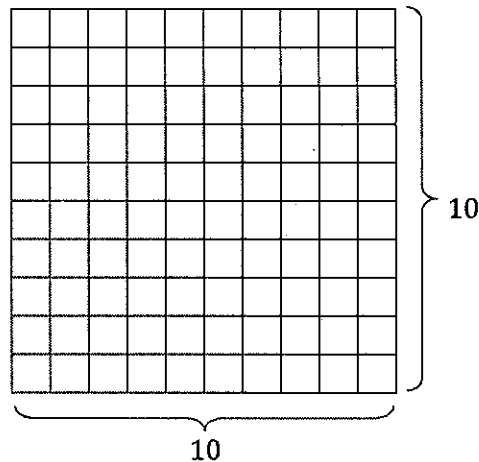

Rewrite each equation in unit form and solve.

3. $80 \times 60 = \underline{4,800}$

$\underline{8} \text{ tens} \times \underline{6} \text{ tens} = \underline{48} \text{ hundreds}$

4. One carton contains 70 eggs. If there are 70 cartons in a crate, how many eggs are in one crate?

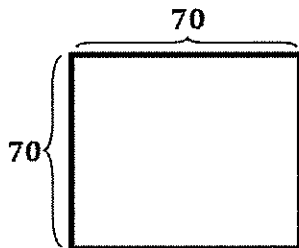

$7 \text{ tens} \times 7 \text{ tens} = 49 \text{ hundreds}$

$70 \times 70 = 4,900$

There are 4,900 eggs in one crate.

G4-M3-Lesson 7

1. Represent the following expression with disks, regrouping as necessary. To the right, record the partial products vertically.

$$4 \times 35$$

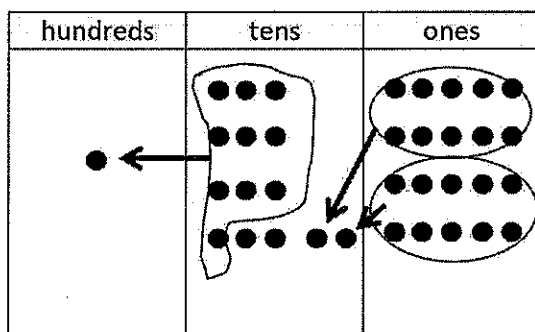

$$\begin{array}{r}
 35 \\
 \times 4 \\
 \hline
 20 \rightarrow 4 \times 5 \text{ ones} \\
 + 120 \rightarrow 4 \times 3 \text{ tens} \\
 \hline
 140
 \end{array}$$

I draw 4 groups of 3 tens 5 ones.
 4 times 5 ones equals 20 ones.
 I compose 20 ones to make 2 tens.
 4 times 3 tens equals 12 tens.
 I compose 10 tens to make 1 hundred.

After multiplying the ones, I record the product. I multiply the tens and record the product. I add these two partial products. My sum is the product of 35×4 .

2. Jillian says she found a shortcut for doing multiplication problems. When she multiplies 3×45 , she says, “ 3×5 is 15 ones, or 1 ten and 5 ones. Then, there’s just 4 tens left in 45, so add it up, and you get 5 tens and 5 ones.” Do you think Jillian’s shortcut works? Explain your thinking in words, and justify your response using a model or partial products.

Sample answer:

Jillian multiplied the ones. She found the first partial product. But she didn’t multiply the tens. She forgot to multiply 4 tens by 3. So, Jillian didn’t get the right second partial product. So, her final product isn’t correct. The product of 3×45 is 135.

$$\begin{array}{r}
 45 \\
 \times 3 \\
 \hline
 15 \rightarrow 3 \times 5 \text{ ones} \\
 + 120 \rightarrow 3 \times 4 \text{ tens} \\
 \hline
 135
 \end{array}$$

G4-M3-Lesson 8

Represent the following with disks, using either method shown in class, regrouping as necessary. Below the place value chart, record the partial product vertically.

1. 5×731

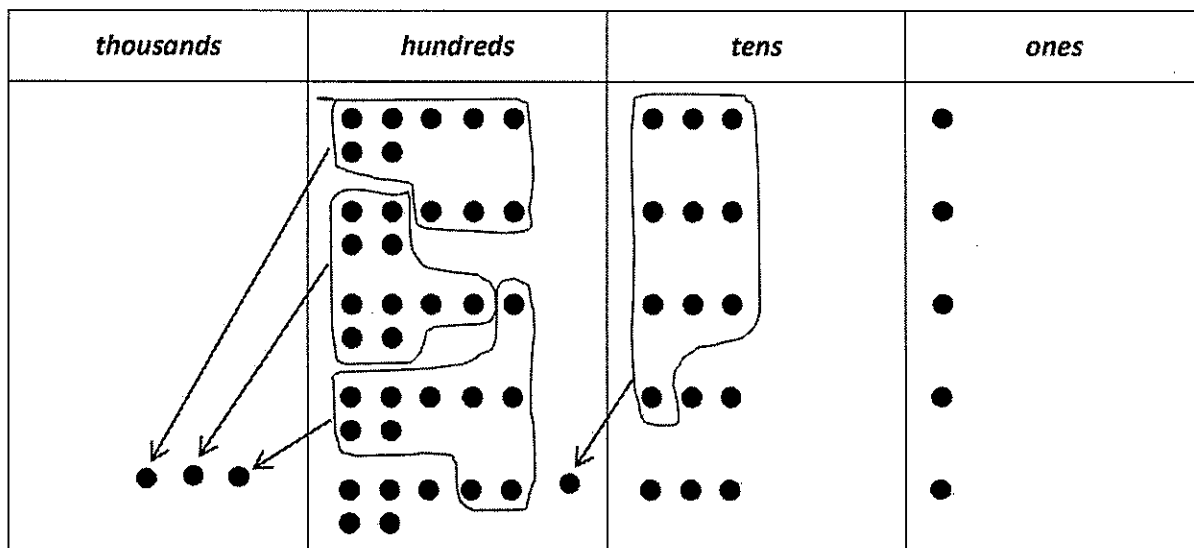

$5 \times 7 \text{ hundreds} + 5 \times 3 \text{ tens} + 5 \times 1 \text{ one}$

$3 \text{ thousands} + 6 \text{ hundreds} + 5 \text{ tens} + 5 \text{ ones} = 3,655$

When there are 10 units in any place, I compose a larger unit.

$$\begin{array}{r}
 731 \\
 \times 5 \\
 \hline
 3655
 \end{array}$$

The partial products mirror the disks on the place value chart. I draw and record the total value of each unit.

2. Janice rides her bike around the block. The block is rectangular with a width of 172 m and a length of 230 m.

a. Determine how many meters Janice rides if she goes around the block one time.

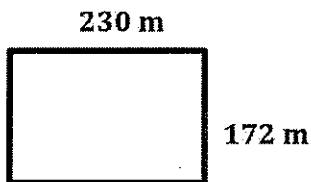

$$\begin{array}{r} 172 \\ + 230 \\ \hline 402 \end{array}$$

$$\begin{array}{r} 402 \\ \times 2 \\ \hline \end{array}$$

4 → 2 × 2 ones

0 → 2 × 0 tens

+ 800 → 2 × 4 hundreds

$$\hline 804$$

$$P = 2 \times (l + w)$$

$$P = 2 \times 402$$

$$P = 804$$

One lap is 804 meters.

b. Determine how many meters Janice rides if she goes around the block three times.

$$\begin{array}{r} 804 \\ \times 3 \\ \hline \end{array}$$

12 → 3 × 4 ones

0 → 3 × 0 tens

+ 2,400 → 3 × 8 hundreds

$$\hline 2,412$$

Janice rides 2,412 meters.

G4-M3-Lesson 9

1. Solve using each method.

No matter which method I choose, I get the same product.

I envision my work with disks on the place value chart when I use the partial products method. I record each partial product on a separate line.

Partial Products	Standard Algorithm
$\begin{array}{r} 215 \\ \times \quad 4 \\ \hline 860 \end{array}$	$\begin{array}{r} 215 \\ \times \quad 4 \\ \hline 860 \end{array}$

When using the standard algorithm, I record the product all on one line.

4 times 5 ones equals 20 ones or 2 tens 0 ones. I record 2 tens on the line in the tens place and 0 ones in the ones place.

2. Solve using the standard algorithm.

a.

$$\begin{array}{r} 205 \\ \times \quad 9 \\ \hline 1,845 \end{array}$$

b.

$$\begin{array}{r} 491 \\ \times \quad 7 \\ \hline 3,437 \end{array}$$

When using the standard algorithm, I multiply the ones first.

7 times 4 hundreds is 28 hundreds. I add 6 hundreds and record 34 hundreds. I cross out the 6 hundreds after I add them.

3. One airline ticket costs \$249. How much will 4 tickets cost?

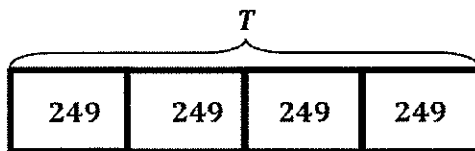

$$\begin{array}{r} 249 \\ \times \quad 4 \\ \hline 996 \end{array}$$

I record 36 ones as 3 tens 6 ones. I write the 3 first and then the 6. It's easy to see 36 since the 3 is written on the line.

$$T = 4 \times 249$$

$$T = 996$$

Four tickets will cost \$996.

G4-M3-Lesson 10

1. Solve using the standard algorithm.

a. 2×52

$$\begin{array}{r} 52 \\ \times 2 \\ \hline 104 \end{array}$$

b. 7×52

$$\begin{array}{r} 52 \\ \times 7 \\ \hline 364 \end{array}$$

I cross out the 1 ten on the line because I've added it to the 35 tens.

c. 4×163

$$\begin{array}{r} 163 \\ \times 4 \\ \hline 652 \end{array}$$

In contrast to the partial products method, I add as I solve, recording the product in a single line.

d. $8 \times 4,861$

$$\begin{array}{r} 4,861 \\ \times 8 \\ \hline 38,888 \end{array}$$

I use unit language to multiply. Eight times 4 thousands is 32 thousands. I add 6 more thousands to make 38 thousands, or 3 ten thousands 8 thousands.

2. Mimi ran 2 miles. Raj ran 3 times as far. There are 5,280 feet in a mile. How many feet did Raj run?

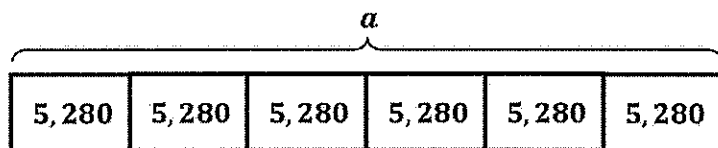
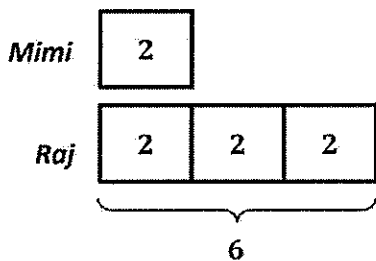

I can choose to solve using a place value chart or using partial products. But using the algorithm is most efficient for me.

$$\begin{array}{r} a = 5,280 \times 6 \\ a = 31,680 \end{array} \quad \begin{array}{r} 5,280 \\ \times 6 \\ \hline 31,680 \end{array}$$

Raj ran 31,680 feet.

G4-M3-Lesson 11

1. Solve the following expression using the standard algorithm, the partial products method, and the area model.

672 × 8
672
× 8

16
560
+4,800

5,376

672
× 8

5 , 3 7 6

600	70	2	
8	4,800	560	16

$8 \times (600 + 70 + 2)$
 $(8 \times 600) + (8 \times 70) + (8 \times 2)$

I see the same partial products in the area model.

I multiply unit by unit when solving using partial products, the algorithm, or the area model. All along I have been using the distributive property! Now I can write it out as an expression to match.

2. Solve using the standard algorithm, the area model, the distributive property, or the partial products method.

Each year, Mr. Hill gives \$5,725 to charity, and Mrs. Hill gives \$752. After 5 years, how much has the couple given to charity?

a	
5,725	752

$a = 5,725 + 752$
 $a = 6,477$

I add to find the total given in charity each year.

p			
6,477			

$p = 6,477 \times 5$
 $p = 32,385$

6,000	400	70	7	
5	30,000	2,000	350	35

$5 \times (6,000 + 400 + 70 + 7)$
 $(5 \times 6,000) + (5 \times 400) + (5 \times 70) + (5 \times 7)$

6,477
× 5

3 2 , 3 8 5

After 5 years, Mr. and Mrs. Hill have given \$32,385 to charity.

G4-M3-Lesson 12

Use the RDW process to solve the following problem.

1. The table shows the cost of bake sale goods. Milan's mom buys 1 brownie, 1 cookie, and 1 slice of cake for each of her 8 children. How much does she spend?

Baked Good	Cost
brownie	59¢
slice of cake	45¢
cookie	27¢

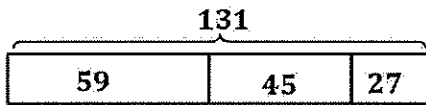

$$\begin{array}{r} 59 \\ + 45 \\ + 27 \\ \hline 131 \end{array}$$

I add and then multiply to solve.

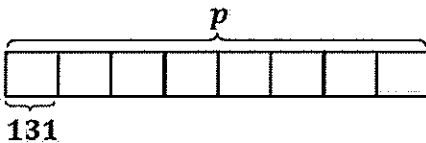

$$p = 131 \times 8$$

$$p = 1,048$$

$$\begin{array}{r} 131 \\ \times 8 \\ \hline 1048 \end{array}$$

Milan's mom spends 1,048¢.

2.

- a. Write an equation that could be used to find the value of c in the tape diagram.

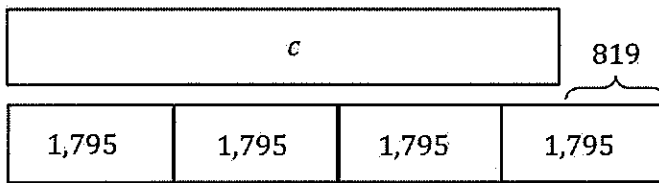

$$c = 4 \times 1,795 - 819$$

I thought of two other equations:

$$c + 819 = 4 \times 1,795$$

or

$$c = (3 \times 1,795) + (1,795 - 819).$$

- b. Write your own word problem to correspond to the tape diagram, and then solve.

Every month, Katrina earns \$1,795.

Kelly earns 4 times as much as Katrina earns. Mary earns \$819 less than Kelly. How much does Mary earn each month?

$$M = (4 \times 1,795) - 819$$

$$M = 7,180 - 819$$

$$M = 6,361$$

Mary earns \$6,361 each month.

$$\begin{array}{r} 1,795 \\ \times 4 \\ \hline 7,180 \\ + 4,000 \\ \hline 11,180 \\ - 819 \\ \hline 10,361 \end{array}$$

I use the partial products method to make sure I record the products of each unit.

G4-M3-Lesson 13

Solve using the RDW process.

1. A banana costs 58¢. A pomegranate costs 3 times as much. What is the total cost of a pomegranate and 5 bananas?

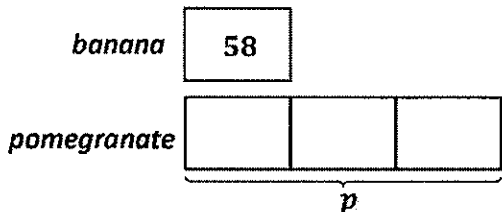

$$p = 3 \times 58$$

$$p = 174$$

$$\begin{array}{r} 58 \\ \times 3 \\ \hline 174 \end{array}$$

If one unit equals 58, then three units equal 174.

I find the cost of 1 pomegranate.

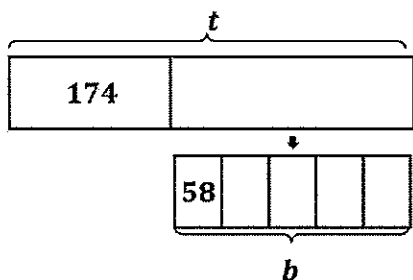

$$b = 5 \times 58$$

$$b = 290$$

$$\begin{array}{r} 58 \\ \times 5 \\ \hline 290 \end{array}$$

$$t = 174 + 290$$

$$t = 464$$

I add to find the total.

I find the cost of 5 bananas.

The total cost of a pomegranate and 5 bananas is 464¢.

2. Mr. Turner gave his 2 daughters \$197 each. He gave his mother \$325. He gave his wife money as well. If Mr. Turner gave a total of \$3,000, how much did he give to his wife?

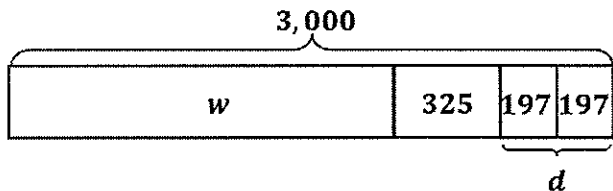

$$w = 3,000 - 719$$

$$w = 2,281$$

$$\begin{array}{r} 197 \\ \times 2 \\ \hline 394 \end{array}$$

$$d = 197 \times 2$$

$$d = 394$$

$$\begin{array}{r} 325 \\ + 394 \\ \hline 719 \end{array}$$

$$\begin{array}{r} 3,000 \\ - 719 \\ \hline 2,281 \end{array}$$

Mr. Turner gave \$2,281 to his wife.

I find the amount Mr. Turner gave to his 2 daughters.

I add to find the total given to his daughters and mother.

I subtract to find the amount he gave to his wife.

G4-M3-Lesson 14

Use the RDW process to solve the following problems.

1. Marco has 19 tortillas. If he uses 2 tortillas for each quesadilla, what is the greatest number of quesadillas he can make? Will he have any extra tortillas? How many?

$19 \div 2$

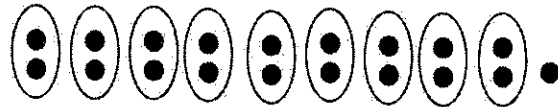

The quotient is 9. The remainder is 1.

I draw groups of 2 tortillas.

He can make up to 9 quesadillas. He will have 1 extra tortilla.

2. Coach Adam puts 31 players into teams of 8. How many teams does he make? If he makes a smaller team with the remaining players, how many players are on that team?

$31 \div 8$

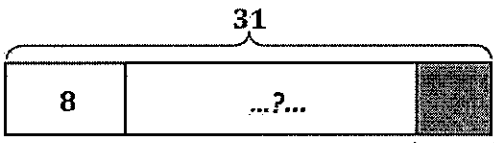

8, 16, 24

I skip count by eights. I stop at the number closest to the total number of players, without going over.

I don't know how many units to draw for my tape, so I write a question mark.

I know that 8 is not a factor of 31, so I anticipate a remainder and recognize the remainder as a shaded portion at the end of the tape diagram.

Coach Adam makes 3 teams. The smaller team has 7 players.

G4-M3-Lesson 15

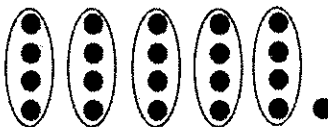
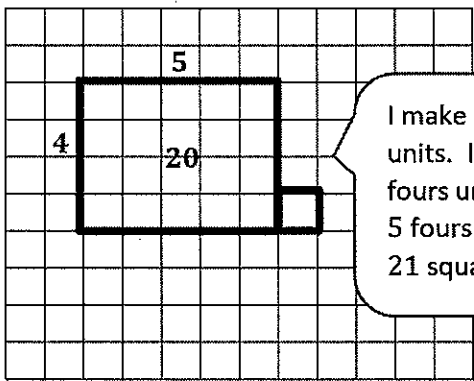
Show division using an array.	Show division using an area model.
<p>1. $21 \div 4$</p>  <p>Quotient = <u>5</u> There are 5 groups of four.</p> <p>Remainder = <u>1</u></p>	 <p style="border: 1px solid black; border-radius: 15px; padding: 5px; display: inline-block; vertical-align: middle;">I make the width 4 units. I count by fours until I get to 20. 5 fours is 20. I outline 21 square units in all.</p> <p>Can you show $21 \div 4$ with one rectangle? <i>no</i> Explain how you showed the remainder. <i>I outlined one more square unit.</i></p>

Solve using an array and area model.

2. $53 \div 7$

a. Array

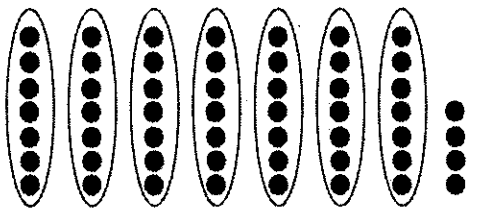

Quotient = 7 Remainder = 4

The area model may be faster to draw, but no matter which model I use, I get the same answer!

b. Area Model

I can draw quickly without grid paper.

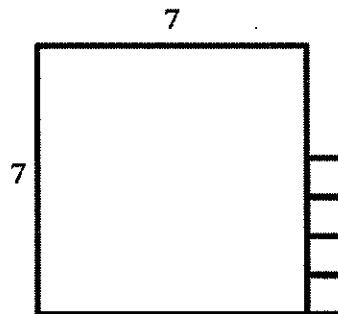

I represent the remainder with 4 more square units.

G4-M3-Lesson 16

Show the division using disks. Relate your work on the place value chart to long division. Check your quotient and remainder by using multiplication and addition.

1. $9 \div 2$

To model, the divisor represents the number of equal groups. The quotient represents the size of the groups.

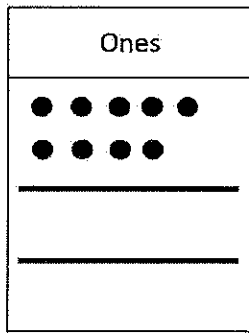

I represent 9 ones, the whole, using place value disks.

I make space on the chart to distribute the disks into 2 equal groups.



9 ones distributed evenly into 2 equal groups is 4 ones in each group. I cross them off as I distribute.

1 one remains because it cannot be distributed evenly into 2. I circle it to show it is a remainder.

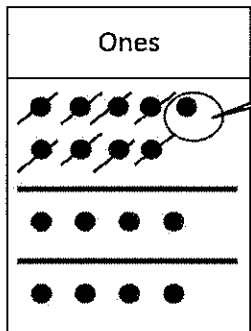

This is the quotient.

$$\begin{array}{r} 4 \text{ R}1 \\ 2 \overline{) 9} \\ \underline{- 8} \\ 1 \end{array}$$

quotient = 4

remainder = 1

Check your work.

$$\begin{array}{r} 4 \quad 8 \\ \times 2 \quad + 1 \\ \hline 8 \quad 9 \end{array}$$

I check my division by multiplying the quotient times the divisor. I add the remainder. The sum is the whole.

2. $87 \div 4$

I represent the whole as 8 tens and 7 ones. I partition the chart into 4 equal groups below.

Tens	Ones

$8 \div 4 = 2$
8 tens distributed evenly among 4 groups is 2 tens.

$$\begin{array}{r} 2 \\ 4 \overline{) 87} \\ - 8 \\ \hline 07 \end{array}$$

$2 \times 4 = 8$
2 tens in each of the 4 groups is 8 tens.

$8 - 8 = 0$
We started with 8 tens and distributed 8 tens evenly. Zero tens and 7 ones remain in the whole.



Tens	Ones

} 2 tens 1 one

$7 \div 4 = 1$
7 ones distributed evenly among 4 groups is 1 one.

$$\begin{array}{r} 2 \ 1 \ R3 \\ 4 \overline{) 87} \\ - 8 \\ \hline 07 \\ - 4 \\ \hline 3 \end{array}$$

$4 \times 1 = 4$
1 one in each of the 4 groups is 4 ones. Only 4 of the 7 ones were evenly distributed.

$7 - 4 = 3$
We started with 7 ones and distributed 4 ones evenly. 3 ones remain in the whole.

I record the remainder next to the quotient.

quotient = 21

remainder = 3

Check your work			
	2	1	
\times		4	
	8	4	
		+	8 4
			3
			8 7

G4-M3-Lesson 17

Show the division using disks. Relate your model to long division. Check your quotient by using multiplication and addition.

1. $5 \div 4$

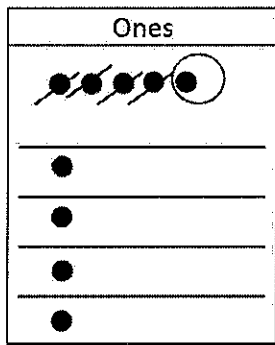

$$\begin{array}{r} 1 \text{ R}1 \\ 4 \overline{) 5} \\ - 4 \\ \hline 1 \end{array}$$

quotient = 1
remainder = 1

Check your work.

$$\begin{array}{r} 4 \quad 4 \\ \times 1 \quad + 1 \\ \hline 4 \quad 5 \end{array}$$

Just like Lesson 16, I model the whole and partition the chart into 4 parts to represent the divisor.

2. $53 \div 4$

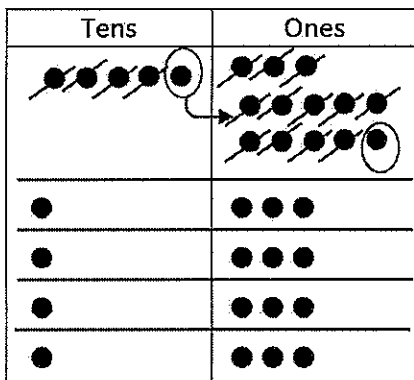

After distributing 4 tens, 1 ten remains. I change 1 ten for 10 ones.

$$\begin{array}{r} 1 \ 3 \ \text{R}1 \\ 4 \overline{) 53} \\ - 4 \\ \hline 13 \\ - 12 \\ \hline 1 \end{array}$$

Now, I have 13 ones. I can distribute 12 ones evenly, but 1 one remains.

quotient = 13
remainder = 1

Check your work.

$$\begin{array}{r} 1 \ 3 \quad 5 \ 2 \\ \times 4 \quad + 1 \\ \hline 5 \ 2 \quad 5 \ 3 \end{array}$$

G4-M3-Lesson 18

Solve using the standard algorithm. Check your quotient and remainder by using multiplication and addition.

1. $69 \div 3$

$$\begin{array}{r} 23 \\ 3 \overline{) 69} \\ \underline{- 6} \\ 09 \\ \underline{- 9} \\ 0 \end{array}$$

$$\begin{array}{r} 23 \\ \times 3 \\ \hline 69 \end{array}$$

69 divided by 3 is 23.
And 23 times 3 is 69.

2. $57 \div 3$

$$\begin{array}{r} 19 \\ 3 \overline{) 57} \\ \underline{- 3} \\ 27 \\ \underline{- 27} \\ 0 \end{array}$$

I notice the divisor is the same in Problems 1 and 2. But the whole 69 is greater than the whole of 57. When the divisor is the same, the larger the whole, the larger the quotient.

I distribute 3 tens. 2 tens remain. After decomposing, 20 ones plus 7 ones is 27 ones.

$$\begin{array}{r} 19 \\ \times 3 \\ \hline 57 \end{array}$$

3. $94 \div 5$

$$\begin{array}{r} 18 \text{ R}4 \\ 5 \overline{) 94} \\ \underline{- 5} \\ 44 \\ \underline{- 40} \\ 4 \end{array}$$

$$\begin{array}{r} 18 \\ \times 5 \\ \hline 90 \end{array} \quad \begin{array}{r} 90 \\ + 4 \\ \hline 94 \end{array}$$

The quotient is 18 with a remainder of 4.

4. $97 \div 7$

$$\begin{array}{r} 13 \text{ R}6 \\ 7 \overline{) 97} \\ \underline{- 7} \\ 27 \\ \underline{- 21} \\ 6 \end{array}$$

When the wholes are nearly the same, the larger the divisor, the smaller the quotient. That's because the whole is divided into more equal groups.

I prove my division is correct by multiplying 13 by 7 and then adding 6 more.

$$\begin{array}{r} 13 \\ \times 7 \\ \hline 91 \end{array} \quad \begin{array}{r} 91 \\ + 6 \\ \hline 97 \end{array}$$

G4-M3-Lesson 19

1. Makhai says that $97 \div 3$ is 30 with a remainder of 7. He reasons this is correct because $(3 \times 30) + 7 = 97$. What mistake has Makhai made? Explain how he can correct his work.

Makhai stopped dividing when he had 7 ones, but he can distribute them into 3 more groups of 2. If he does so, he can make 3 groups of 32 instead of just 30.

$$\begin{array}{r}
 32 \text{ R}1 \\
 3 \overline{) 97} \\
 \underline{- 9} \\
 07 \\
 \underline{- 6} \\
 1
 \end{array}$$

There are not enough ones to distribute into 3 groups. I record 1 one as the remainder.

2. Four friends evenly share 52 dollars.
- a. They have 5 ten-dollar bills and 2 one-dollar bills. Draw a picture to show how the bills will be shared. Will they have to make change at any stage?

I unbundle a ten by drawing an arrow from the remaining 1 ten to 10 ones.

Yes, they will have to make change for 1 ten-dollar bill. Before they can share it, they must exchange it for 10 one-dollar bills.

1 ten 3 ones = 13

- b. Explain how they share the money evenly.
- Each friend gets 1 ten-dollar bill and 3 one-dollar bills.*

3. Imagine you are writing a magazine article describing how to solve the problem $43 \div 3$ to new fourth graders. Write a draft to explain how you can keep dividing after getting a remainder of 1 ten in the first step.

Sample answer: This is how you divide 43 by 3. Think of it like 4 tens 3 ones divided into 3 groups. First, you want to distribute the tens. You can distribute 3 tens. Each group will have 1 ten. There will be 1 ten left over. That's okay. You can keep dividing. Just change 1 ten for 10 ones. Now you have 13 ones altogether. You can distribute 12 ones evenly. 3 groups of 4 ones is 12 ones. 1 one is remaining. So, your quotient is 14 R1. And that's how you divide 43 by 3.

$$\begin{array}{r}
 14 \text{ R}1 \\
 3 \overline{) 43} \\
 \underline{- 3} \\
 13 \\
 \underline{- 12} \\
 1
 \end{array}$$

G4-M3-Lesson 20

1. Paco solved a division problem by drawing an area model.
 - a. Look at the area model. What division problem did Paco solve?

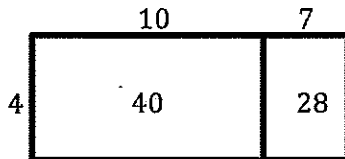

$$68 \div 4 = 17$$

I add the areas to find the whole. The width is the divisor. I add the two lengths to find the quotient.

- b. Show a number bond to represent Paco's area model. Start with the total, and then show how the total is split into two parts. Below the two parts, represent the total length using the distributive property, and then solve.

Dividing smaller numbers is easier for me than solving $68 \div 4$. I can solve mentally because these are easy facts.

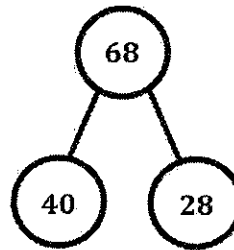

In the number bond, I record the whole (68) split into two parts (40 and 28).

$$\begin{aligned} & (\underline{40} \div \underline{4}) + (\underline{28} \div \underline{4}) \\ & = \underline{10} + \underline{7} \\ & = \underline{17} \end{aligned}$$

2. Solve $76 \div 4$ using an area model. Explain the connection of the distributive property to the area model using words, pictures, or numbers.

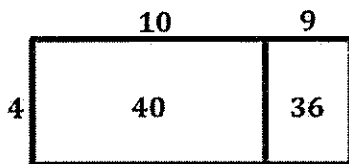

$$\begin{aligned} & (40 \div 4) + (36 \div 4) \\ & = 10 + 9 \\ & = 19 \end{aligned}$$

The area model is like a picture for the distributive model. Each rectangle represents a smaller division expression that we write in parentheses. The width of the rectangle is the divisor in each sentence. The two lengths are added together to get the quotient.

I think of 4 times how many lengths of ten get me close to 7 tens in the whole: 1 ten. Then, 4 times how many lengths of ones gets me close to the remaining 36 ones: 9 ones.

G4-M3-Lesson 21

1. Yahya solved the following division problem by drawing an area model.

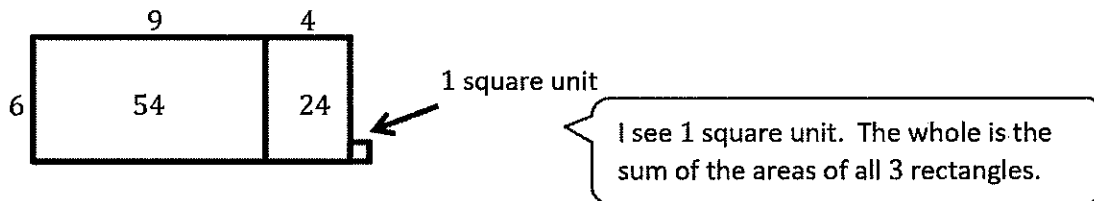

- a. What division problem did he solve? $79 \div 6$
- b. Show how Yahya's model can be represented using the distributive property.

$$\begin{aligned}
 &(54 \div 6) + (24 \div 6) \\
 &= 9 + 4 \\
 &= 13 \\
 &(6 \times 13) + 1 = 79
 \end{aligned}$$

I remember to add a remainder of 1.

Solve the following problems using the area model. Support the area model with long division or the distributive property.

<p>2. $71 \div 5$</p> $ \begin{aligned} &(60 \div 5) + (10 \div 5) \\ &= 12 + 2 \\ &= 14 \\ &(14 \times 5) + 1 = 71 \end{aligned} $	<p>3. $85 \div 6$</p> <div style="float: right; text-align: right;"> $\begin{array}{r} 14 \ R1 \\ 6 \overline{) 85} \\ \underline{- 6} \\ 25 \\ \underline{- 24} \\ 1 \end{array}$ </div> <p style="border: 1px solid black; border-radius: 15px; padding: 5px; display: inline-block;">The area of the smaller rectangle is the same as the number of distributed ones in the algorithm.</p>
---	--

4. Eighty-nine marbles were placed equally in 4 bags. How many marbles were in each bag? How many marbles are left over?

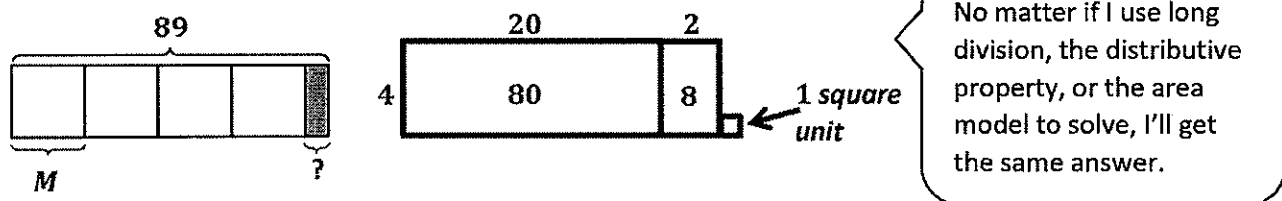

There are 22 marbles in each bag. 1 marble is left over.

G4-M3-Lesson 22

1. Record the factors of the given numbers as multiplication sentences and as a list in order from least to greatest. Classify each as prime (P) or composite (C).

	Multiplication Sentences	Factors	P or C
a.	5 $1 \times 5 = 5$	The factors of 5 are 1, 5	P
b.	18 $1 \times 18 = 18$ $2 \times 9 = 18$ $3 \times 6 = 18$	The factors of 18 are 1, 2, 3, 6, 9, 18	C

I know a number is prime if it has only two factors. I know a number is composite if it has more than two factors.

2. Find all factors for the following number, and classify the number as prime or composite. Explain your classification of prime or composite.

Factor Pairs for 12	
1	12
2	6
3	4

12 is composite. I know that it is composite because it has more than two factors.

I think of the multiplication facts that have a product of 12.

3. Jenny has 25 beads to divide evenly among 4 friends. She thinks there will be no leftovers. Use what you know about factor pairs to explain whether or not Jenny is correct.

Jenny is not correct. There will be leftovers. I know this because if 4 is one of the factors, there is no whole number that multiplies by 4 to get 25 as a product. There will be one bead left over.

$4 \times 6 = 24$ and $4 \times 7 = 28$. There is no factor pair for 4 that results in a product of 25.

G4-M3-Lesson 23

1. Explain your thinking, or use division to answer the following.

<p>Is 2 a factor of 96?</p> <p><i>Yes. 96 is an even number. 2 is a factor of every even number.</i></p>	<p>Is 3 a factor of 96?</p> $\begin{array}{r} 32 \\ 3 \overline{) 96} \\ \underline{- 9} \\ 06 \\ \underline{- 6} \\ 0 \end{array}$ <p><i>Yes, 3 is a factor of 96. When I divide 96 by 3, my answer is 32.</i></p>
<p>Is 4 a factor of 96?</p> $\begin{array}{r} 24 \\ 4 \overline{) 96} \\ \underline{- 8} \\ 16 \\ \underline{- 16} \\ 0 \end{array}$ <p><i>Yes, 4 is a factor of 96. When I divide 96 by 4, my answer is 24.</i></p>	<p>Is 5 a factor of 96?</p> <p><i>No, 5 is not a factor of 96. 96 does not have a 5 or 0 in the ones place. All numbers that have a 5 as a factor have a 5 or 0 in the ones place.</i></p>

I use what I know about factors to solve. Thinking about whether 2 is a factor or 5 is a factor is easy. Threes and fours are harder, so I divide to see if they are factors. 96 is divisible by both 3 and 4, so they are both factors of 96.

2. Use the associative property to find more factors of 28 and 32.

a. $28 = 14 \times 2$

$$= (\underline{7} \times 2) \times 2$$

$$= \underline{7} \times (2 \times 2)$$

$$= \underline{7} \times 4$$

$$= \underline{28}$$

b. $32 = \underline{8} \times 4$

$$= (\underline{2} \times 4) \times 4$$

$$= \underline{2} \times (4 \times 4)$$

$$= \underline{2} \times 16$$

$$= \underline{32}$$

I find more factors of the whole number by breaking down one of the factors into smaller parts and then associating the factors differently using parentheses.

3. In class, we used the associative property to show that when 6 is a factor, then 2 and 3 are factors, because $6 = 2 \times 3$. Use the fact that $12 = 2 \times 6$ to show that 2 and 6 are factors of 36, 48, and 60.

$$36 = 12 \times 3$$

$$= (2 \times 6) \times 3$$

$$= 2 \times (6 \times 3)$$

$$= 2 \times 18$$

$$= 36$$

$$48 = 12 \times 4$$

$$= (2 \times 6) \times 4$$

$$= 2 \times (6 \times 4)$$

$$= 2 \times 24$$

$$= 48$$

$$60 = 12 \times 5$$

$$= (2 \times 6) \times 5$$

$$= 2 \times (6 \times 5)$$

$$= 2 \times 30$$

$$= 60$$

I rewrite the number sentences, substituting 2×6 for 12. I can move the parentheses because of the associative property and then solve. This helps to show that both 2 and 6 are factors of 36, 48, and 60.

4. The first statement is false. The second statement is true. Explain why using words, pictures, or numbers.

If a number has 2 and 8 as factors, then it has 16 as a factor.

If a number has 16 as a factor, then both 2 and 8 are factors.

The first statement is false. For example, 8 has both 2 and 8 as factors, but it does not have 16 as a factor. The second statement is true. Any number that can be divided exactly by 16 can also be divided by 2 and 8 instead since $16 = 2 \times 8$. Example: $2 \times 16 = 32$

$$2 \times (2 \times 8) = 32$$

I give examples to help with my explanation.

G4-M3-Lesson 24

1. Write the multiples of 3 starting from 36: Time yourself for 1 minute. See how many multiples you can write.

36, 39, 42, 45, 48, 51, 54, 57, 60, 63, 66, 69, 72, 75, 78, 81, 84, 87,
90, 93, 96, 99, 102, 105, 108, 111, 114

I skip-count by threes starting with 36.

2. List the numbers that have 28 as a multiple.

1, 2, 4, 7, 14, 28

This is just like finding the factor pairs of a number. If I say "28" when I skip-count by a number, that means 28 is a multiple of that number.

3. Use mental math, division, or the associative property to solve.

a. Is 15 a multiple of 3? yes Is 3 a factor of 15? yes

$3 \times 5 = 15$, so 3 is a factor of 15.

b. Is 34 a multiple of 6? no Is 6 a factor of 34? no

c. Is 32 a multiple of 8? yes Is 32 a factor of 8? no

If a number is a multiple of another number, it means that, when I skip-count, I say that number.

8 is a factor of 32, but 32 is not a factor of 8.

4. Follow the directions below.

1	2	△3	□4	5	△6	7	□8	△9	○10
11	△12	13	14	△15	□16	17	△18	19	□20
△21	22	23	△24	25	26	△27	□28	29	△30
31	□32	△33	34	35	△36	37	38	△39	□40
41	△42	43	□44	△45	46	47	△48	49	○50
△51	□52	53	△54	55	□56	△57	58	59	△60
61	62	△63	□64	65	△66	67	□68	△69	○70
71	△72	73	74	△75	□76	77	△78	79	□80
△81	82	83	△84	85	86	△87	□88	89	△90
91	□92	△93	94	95	△96	97	98	△99	□100

- a. Circle the multiples of 10. When a number is a multiple of 10, what do you notice about the number in the ones place?

When a number is a multiple of 10, the number in the ones place is always a zero.

- b. Draw a square around the multiples of 4. When a number is a multiple of 4, what are the possible numbers in the ones digit?

When a number is a multiple of 4, the possible number in the ones digit is 2, 4, 6, 8, or 0.

- c. Put a triangle on the multiples of 3. Choose one. What do you notice about the sum of the digits? Choose another one. What do you notice about the sum of the digits?

15 → *The sum of the digits is 6.*

75 → *The sum of the digits is 12.*

If I look at more multiples of 3, I see that the sum of their digits is 3, 6, 9, 12, 15, or 18. Each of those numbers is a multiple of 3.

G4-M3-Lesson 25

1. Follow the directions.

Shade the number 1.

- Circle the first unmarked number.
- Cross off every multiple of that number except the one you circled. If it's already crossed off, skip it.
- Repeat Steps (a) and (b) until every number is either circled or crossed off.
- Shade every crossed out number.

1	2	3	4	5	6	7	8	9	10
11	12	13	14	15	16	17	18	19	20
21	22	23	24	25	26	27	28	29	30
31	32	33	34	35	36	37	38	39	40
41	42	43	44	45	46	47	48	49	50
51	52	53	54	55	56	57	58	59	60
61	62	63	64	65	66	67	68	69	70
71	72	73	74	75	76	77	78	79	80
81	82	83	84	85	86	87	88	89	90
91	92	93	94	95	96	97	98	99	100

I cross off every multiple of 2 except for the number 2.

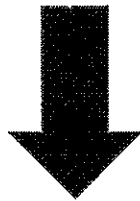

1	2	3	4	5	6	7	8	9	10
11	12	13	14	15	16	17	18	19	20
21	22	23	24	25	26	27	28	29	30
31	32	33	34	35	36	37	38	39	40
41	42	43	44	45	46	47	48	49	50
51	52	53	54	55	56	57	58	59	60
61	62	63	64	65	66	67	68	69	70
71	72	73	74	75	76	77	78	79	80
81	82	83	84	85	86	87	88	89	90
91	92	93	94	95	96	97	98	99	100

I circle 3 because it is the next number that is not circled or crossed off. I cross off every multiple of 3 except for the number 3. I skip-count by threes to find the multiples.

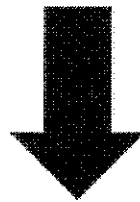

1	2	3	4	5	6	7	8	9	10
11	12	13	14	15	16	17	18	19	20
21	22	23	24	25	26	27	28	29	30
31	32	33	34	35	36	37	38	39	40
41	42	43	44	45	46	47	48	49	50
51	52	53	54	55	56	57	58	59	60
61	62	63	64	65	66	67	68	69	70
71	72	73	74	75	76	77	78	79	80
81	82	83	84	85	86	87	88	89	90
91	92	93	94	95	96	97	98	99	100

I continue the process, first for the multiples of 5 and then for the multiples of 7.

I circle 11 because 11 is the next number that is not circled or crossed off. I notice that every multiple of 11 is already crossed off.

I don't have to cross off the multiples of 13 because they are crossed off already.

I realize that when I circle any of the other numbers that are not already crossed off their multiples have already been crossed off.

I shade every crossed out number.

I see that this process helps me to find the numbers from 1 to 100 that are prime and the numbers from 1 to 100 that are composite.

G4-M3-Lesson 26

1. Draw place value disks to represent the following problems. Rewrite each in unit form and solve.

a. $80 \div 4 = \underline{20}$

$8 \text{ tens} \div 4 = \underline{2 \text{ tens}}$

2 tens is the same as 20.

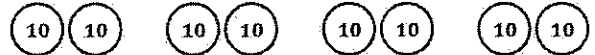

I distribute 8 tens into 4 groups. There are 2 tens in each group.

b. $800 \div 4 = \underline{200}$

$8 \text{ hundreds} \div 4 = \underline{2 \text{ hundreds}}$

I think of 800 in unit form as 8 hundreds.



8 hundreds divided equally into 4 groups is 2 hundreds.

c. $150 \div 3 = \underline{50}$

$15 \text{ tens} \div 3 = \underline{5 \text{ tens}}$

I think of 150 as 1 hundred 5 tens, but that doesn't help me to divide because I can't partition a hundreds disk into 3 equal groups. To help me to divide, I think of 150 as 15 tens.



d. $1,500 \div 3 = \underline{500}$

$15 \text{ hundreds} \div 3 = \underline{5 \text{ hundreds}}$

This is just like the last problem except the unit is hundreds instead of tens.



2. Solve for the quotient. Rewrite each in unit form.

<p>a. $900 \div 3 = 300$</p> <p><i>9 hundreds</i> $\div 3$ = <i>3 hundreds</i></p>	<p>b. $140 \div 2 = 70$</p> <p><i>14 tens</i> $\div 2$ = <i>7 tens</i></p>	<p>c. $1,500 \div 5 = 300$</p> <p><i>15 hundreds</i> $\div 5$ = <i>3 hundreds</i></p>	<p>d. $200 \div 5 = 40$</p> <p><i>20 tens</i> $\div 5$ = <i>4 tens</i></p>
--	--	---	--

These problems are very similar to what I just did. The difference is that I do not draw disks. I rewrite the numbers in unit form to help me solve.

3. An ice cream shop sold \$2,800 of ice cream in August, which was 4 times as much as was sold in May. How much ice cream was sold at the ice cream shop in May?

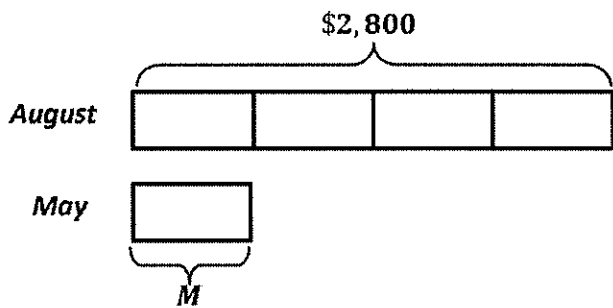

I draw a tape diagram to show the ice cream sales for the month of August and the month of May. The tape for August is 4 times as long as the tape for May. 2,800 in unit form is 28 hundreds. If 4 units is 28 hundreds, 1 unit must be $28 \text{ hundreds} \div 4$. Since May is equal to 1 unit, the ice cream sales for May was \$700.

$28 \text{ hundreds} \div 4 = 7 \text{ hundreds}$

\$700 of ice cream was sold at the ice cream shop in May.

G4-M3-Lesson 27

Divide. Model using place value disks, and record using the algorithm.

$$426 \div 3$$

hundreds	tens	ones
● ● ● ●	● ●	● ● ● ● ● ● ●

I represent 426 as 4 hundreds 2 tens 6 ones.

I make space on the chart to distribute the disks into 3 equal groups.

hundreds	tens	ones
● ● ● ○	● ●	● ● ● ● ● ● ●
●		
●		
●		

I remember from Lesson 16 to divide starting in the largest unit.

4 hundreds divided by 3 is 1 hundred.

1 hundred in each group times 3 groups is 3 hundreds.

We started with 4 hundreds and evenly divided 3 hundreds. 1 hundred remains, which I've circled.

$$\begin{array}{r} 1 \\ 3 \overline{) 426} \\ \underline{- 3} \\ 1 \end{array}$$

hundreds	tens	ones
•		
•		
•		



hundreds	tens	ones
•	•••••	••
•	•••••	••
•	•••••	••

$$\begin{array}{r} 1 \\ 3 \overline{) 426} \\ - 3 \\ \hline 12 \end{array}$$

I remember from Lesson 17 that when there are remaining units that can't be divided, I decompose them as 10 of the next smallest unit. So 1 hundred is decomposed as 10 tens. Now there are 12 tens to divide.

$$\begin{array}{r} 142 \\ 3 \overline{) 426} \\ - 3 \\ \hline 12 \\ - 12 \\ \hline 06 \\ - 6 \\ \hline 0 \end{array}$$

I continue to distribute tens and ones, and I record each step of the algorithm.

1 hundred 4 tens 2 ones

The value in each group equals the quotient.

G4-M3-Lesson 28

1. Divide. Check your work by multiplying. Draw disks on a place value chart as needed.

a. $217 \div 4$

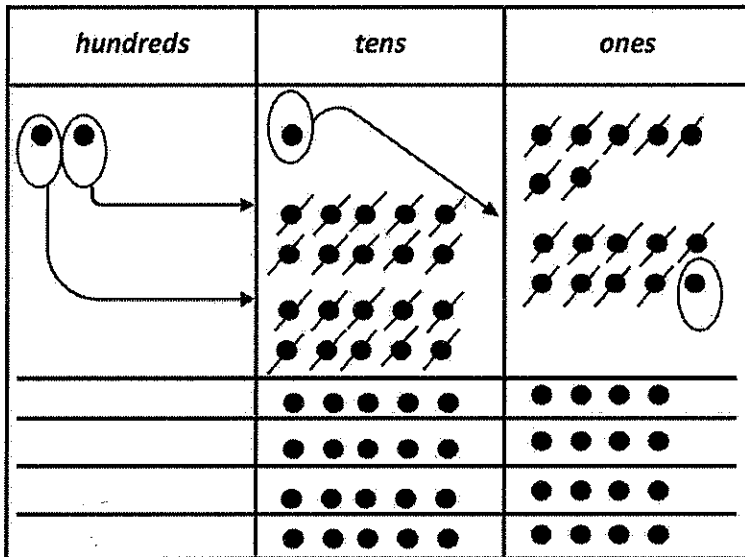

Quotient = 54

Remainder = 1

$$\begin{array}{r} 54 \\ \times 4 \\ \hline 216 \end{array}$$

$$\begin{array}{r} 216 \\ + 1 \\ \hline 217 \end{array}$$

5 tens 4 ones

I can't distribute 2 hundreds evenly among the 4 groups. I decompose each hundred as 10 tens. Now I have 21 tens.

I check my answer by multiplying the quotient and the divisor, and then I add the remainder. My answer of 217 matches the whole in the division expression.

b. $743 \div 3$

$$\begin{array}{r} 247 \text{ R}2 \\ 3 \overline{) 743} \\ - 6 \\ \hline 14 \\ - 12 \\ \hline 23 \\ - 21 \\ \hline 2 \end{array}$$

$$\begin{array}{r} 247 \\ \times 3 \\ \hline 741 \end{array} \quad \begin{array}{r} 741 \\ + 2 \\ \hline 743 \end{array}$$

I visualize each step on the place value chart as I record the steps of the algorithm.

2. Constance ran 620 meters around the 4 sides of a square field. How many meters long was each side of the field?

$$\begin{array}{r}
 155 \\
 4 \overline{) 620} \\
 \underline{- 4} \\
 22 \\
 \underline{- 20} \\
 20 \\
 \underline{- 20} \\
 0
 \end{array}$$

$$\begin{array}{r}
 155 \\
 \times 4 \\
 \hline
 620
 \end{array}$$

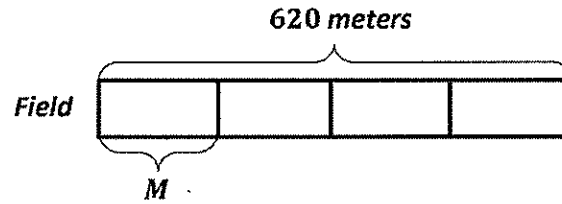

Each side of the field was 155 meters.

G4-M3-Lesson 29

1. Divide, and then check using multiplication.

$$3,268 \div 4$$

$$\begin{array}{r} 817 \\ 4 \overline{) 3,268} \\ \underline{- 32} \\ 06 \\ \underline{- 4} \\ 28 \\ \underline{- 28} \\ 0 \end{array}$$

I divide just as I learned to in Lessons 16, 17, 27, and 28. The challenge now is that the whole is larger, so I record the steps of the algorithm using long division and not using the place value chart.

$$\begin{array}{r} 817 \\ \times 4 \\ \hline 3,268 \end{array}$$

I check the answer by multiplying the quotient and the divisor. The product is equal to the whole.

2. A school buys 3 boxes of pencils. Each box has an equal number of pencils. There are 4,272 pencils altogether. How many pencils are in 2 boxes?

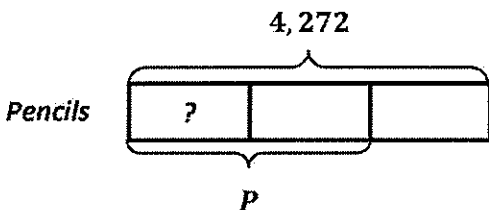

3 units are equal to 4,272 pencils. I need to solve for how many pencils are in 2 units.

$$\begin{array}{r} 1,424 \\ 3 \overline{) 4,272} \\ \underline{- 3} \\ 12 \\ \underline{- 12} \\ 07 \\ \underline{- 6} \\ 12 \\ \underline{- 12} \\ 0 \end{array}$$

$$\begin{array}{r} 1,424 \\ \times 2 \\ \hline 2,848 \end{array}$$

There are 2,848 pencils in 2 boxes.

I multiply by 2 to determine how many pencils are in 2 units.

I find how many pencils are in 1 unit by dividing 4,272 by 3. There are 1,424 pencils in 1 unit.

G4-M3-Lesson 30

Divide. Check your solutions by multiplying.

1. $705 \div 2$

$$\begin{array}{r} 352 \text{ R1} \\ 2 \overline{) 705} \\ - 6 \\ \hline 10 \\ - 10 \\ \hline 05 \\ - 4 \\ \hline 1 \end{array}$$

I decompose 1 hundred as 10 tens. There are no other tens to distribute. So I keep dividing, this time in the tens.

Once I divide the 10 tens, there are no tens remaining. But I must keep dividing. There are still 5 ones to divide.

$$\begin{array}{r} 352 \\ \times 2 \\ \hline 704 \end{array}$$

$$\begin{array}{r} 704 \\ + 1 \\ \hline 705 \end{array}$$

2. $6,250 \div 5$

$$\begin{array}{r} 1250 \\ 5 \overline{) 6,250} \\ - 5 \\ \hline 12 \\ - 10 \\ \hline 25 \\ - 25 \\ \hline 00 \\ - 0 \\ \hline 0 \end{array}$$

This time when I divide, there are no ones to distribute. 0 ones divided by 5 is 0 ones. I place a 0 in the ones place of the quotient to show that there are no ones.

$$\begin{array}{r} 1,250 \\ \times 5 \\ \hline 6,250 \end{array}$$

3. $3,220 \div 4$

$$\begin{array}{r} 805 \\ 4 \overline{) 3,220} \\ - 3 \\ \hline 02 \\ - 0 \\ \hline 20 \\ - 20 \\ \hline 0 \end{array}$$

2 tens can't be evenly divided by 4, so I record 0 tens in the quotient. But I must continue the steps of the algorithm: 0 tens times 4 equals 0 tens. 2 tens minus 0 tens is 2 tens.

$$\begin{array}{r} 805 \\ \times 4 \\ \hline 3,220 \end{array}$$

G4-M3-Lesson 31

Solve the following problems. Draw tape diagrams to help you solve. Identify if the group size or the number of groups is unknown.

- 700 liters of water was shared equally among 4 aquariums. How many liters of water does each aquarium have?

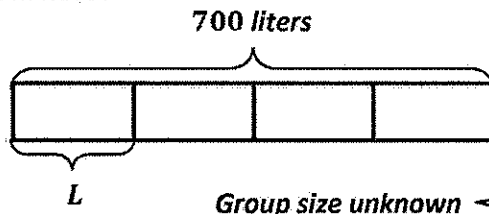

I draw a tape diagram to show 4 aquariums. I need to find the value of each aquarium, or the size of the group.

$$\begin{array}{r}
 175 \\
 4 \overline{) 700} \\
 \underline{- 4} \\
 30 \\
 \underline{- 28} \\
 20 \\
 \underline{- 20} \\
 0
 \end{array}$$

I divide 700 by 4 to find the value of 1 aquarium, or group.

Each aquarium has 175 liters of water.

- Emma separated 824 donuts into boxes. Each box contained 4 donuts. How many boxes of donuts did Emma fill?

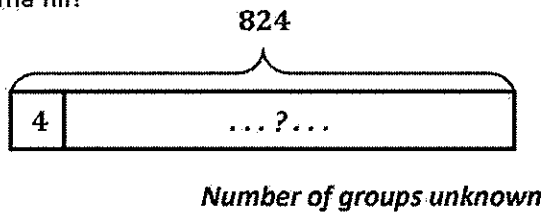

I do not know how many boxes were filled. I show one group of 4. I draw three dots, a question mark, and three dots to indicate that the groups of 4 continue. The number of groups is unknown.

$$\begin{array}{r}
 206 \\
 4 \overline{) 824} \\
 \underline{- 8} \\
 02 \\
 \underline{- 0} \\
 24 \\
 \underline{- 24} \\
 0
 \end{array}$$

Emma filled 206 boxes of donuts.

I divide 824 by 4 to find the number of groups.

G4-M3-Lesson 32

Solve the following problems. Draw tape diagrams to help you solve. If there is a remainder, shade in a small portion of the tape diagram to represent that portion of the whole.

- The clown has 1,649 balloons. It takes 8 balloons to make a balloon animal. How many balloon animals can the clown make?

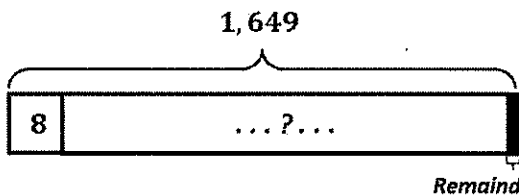

I know the total and that the size of the groups is 8 balloons. I need to determine the number of groups. I divide 1,649 by 8.

$$\begin{array}{r}
 206 \text{ R}1 \\
 8 \overline{) 1,649} \\
 \underline{- 16} \\
 04 \\
 \underline{- 0} \\
 49 \\
 \underline{- 48} \\
 1
 \end{array}$$

There is 1 balloon remaining. That is not enough to make another balloon animal. The clown can make 206 balloon animals. I shade a portion of the tape diagram to represent the remainder.

The clown can make 206 balloon animals.

- In 7 days, Cassidy threw a total of 609 pitches. If she threw the same number of pitches each day, how many pitches did she throw in one day?

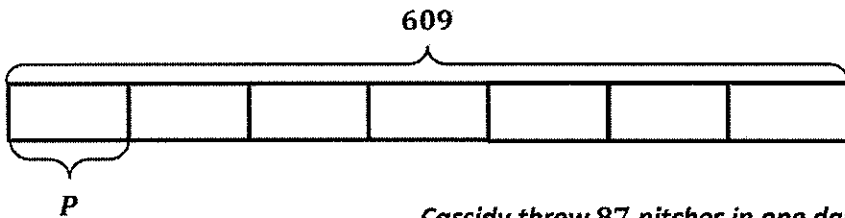

$$\begin{array}{r}
 87 \\
 7 \overline{) 609} \\
 \underline{- 56} \\
 49 \\
 \underline{- 49} \\
 0
 \end{array}$$

Cassidy threw 87 pitches in one day.

I know the total and that the number of groups is 7 days. I need to determine the size of the groups. I divide 609 by 7.

G4-M3-Lesson 33

1. Tyler solved a division problem by drawing this area model.

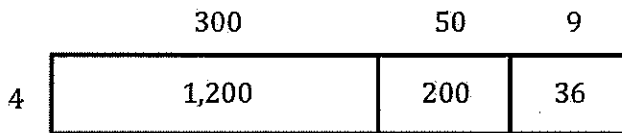

The total area is $1,200 + 200 + 36 = 1,436$. The width is 4. The length is $300 + 50 + 9 = 359$.
 $A \div w = l$.

a. What division problem did he solve?

Tyler solved $1,436 \div 4 = 359$.

b. Show a number bond to represent Tyler's area model, and represent the total length using the distributive property.

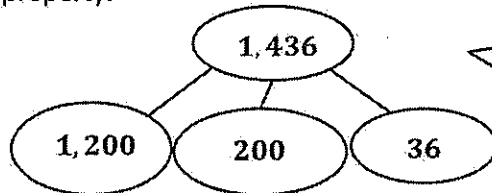

My number bond shows the same whole and parts as the area model. To represent the length, I divide each of the smaller areas by the width of 4.

$$\begin{aligned} & (1,200 \div 4) + (200 \div 4) + (36 \div 4) \\ &= 300 + 50 + 9 \\ &= 359 \end{aligned}$$

I decompose the area of 591 into smaller parts that are easy to divide by 3. I start with the hundreds. I distribute 3 hundreds. The area remaining to distribute is 291. I distribute 27 tens. The area remaining to distribute is 21 ones. I distribute the ones. I have a side length of $100 + 90 + 7 = 197$.

2.

a. Draw an area model to solve $591 \div 3$.

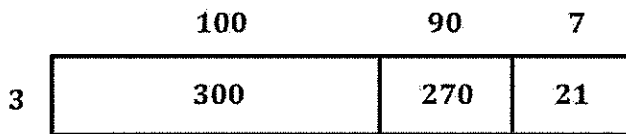

$$591 \div 3 = 197$$

3 hundreds, 27 tens, and 21 ones are all multiples of 3, which is the width and divisor.

- b. Draw a number bond to represent this problem.

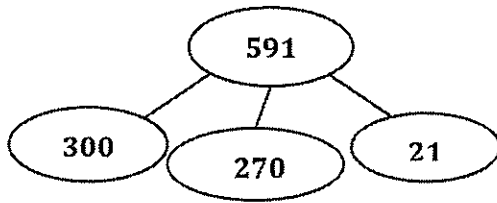

$$\begin{aligned} & (300 \div 3) + (270 \div 3) + (21 \div 3) \\ &= 100 + 90 + 7 \\ &= 197 \end{aligned}$$

My number bond shows the same whole and parts as the area model. To represent the length, I divide each of the smaller areas by the width of 3. I get $100 + 90 + 7 = 197$.

- c. Record your work using the long division algorithm.

$$\begin{array}{r} 197 \\ 3 \overline{) 591} \\ \underline{- 3} \\ 29 \\ \underline{- 27} \\ 21 \\ \underline{- 21} \\ 0 \end{array}$$

3. Use the associative property without place value disks to solve.

$$\begin{aligned}
 &60 \times 54 \\
 &= (6 \times 10) \times 54 \\
 &= 6 \times (10 \times 54) \\
 &= 3,240
 \end{aligned}$$

$$\begin{array}{r}
 540 \\
 \times 6 \\
 \hline
 3240
 \end{array}$$

I rename 60 as 6×10 . Ten times as many as 54 ones is 54 tens. I multiply 6 times 540.

4. Use the distributive property to solve the following. Distribute the second factor.

$$\begin{aligned}
 &40 \times 56 \\
 &= (40 \times 50) + (40 \times 6) \\
 &= 2,000 + 240 \\
 &= 2,240
 \end{aligned}$$

I use unit language to help me solve mentally. Four tens times 5 tens is 20 hundreds. And 4 tens times 6 ones is 24 tens.

G4-M3-Lesson 35

1. Use an area model to represent the following expression. Then, record the partial products vertically and solve.

40×27

I write 40 as the width and decompose 27 as 20 and 7 for the length.

	20	7
40	40×20 <i>4 tens \times 2 tens</i> <i>8 hundreds</i> 800	40×7 <i>4 tens \times 7 ones</i> <i>28 tens</i> 280

I solve for each of the smaller areas.

	27
×	40
	280
+	800
	1,080

I record the partial products. The partial products have the same value as the areas of the smaller rectangles.

2. Visualize the area model, and solve the following expression numerically.

30×66

	66
×	30
	180
+	1,800
	1,980

To solve, I visualize the area model. I see the width as 30 and the length as $60 + 6$. $3 \text{ tens} \times 6 \text{ ones} = 18 \text{ tens}$. $3 \text{ tens} \times 6 \text{ tens} = 18 \text{ hundreds}$. I record the partial products. I find the total. $180 + 1,800 = 1,980$.

G4-M3-Lesson 36

1.

- a. In each of the two models pictured below, write the expressions that determine the area of each of the four smaller rectangles.

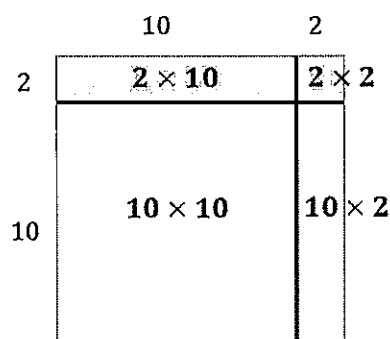
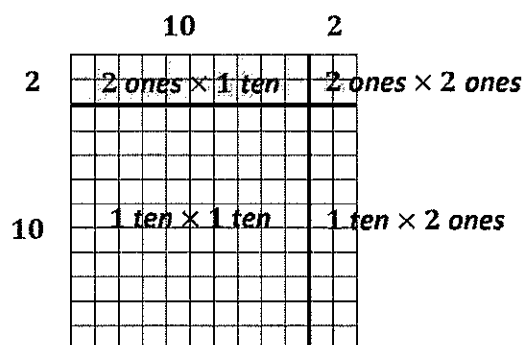

I write the expressions that determine the area of each of the four smaller rectangles. The area of each smaller rectangle is equal to its width times its length. I can write the expressions in unit form or standard form.

- b. Using the distributive property, rewrite the area of the large rectangle as the sum of the areas of the four smaller rectangles. Express the area first in number form and then read it in unit form.

$$12 \times 12 = (2 \times \underline{2}) + (2 \times \underline{10}) + (10 \times \underline{2}) + (10 \times \underline{10})$$

I write the expressions of the areas of the four smaller rectangles. I use the area models to help me. I say, " $12 \times 12 = (2 \text{ ones} \times 2 \text{ ones}) + (2 \text{ ones} \times 1 \text{ ten}) + (1 \text{ ten} \times 2 \text{ ones}) + (1 \text{ ten} \times 1 \text{ ten}).$ "

2. Use an area model to represent the following expression. Record the partial products vertically and solve.

15×33

	30	3
5	<i>5 ones</i> × <i>3 tens</i>	<i>5 ones</i> × <i>3 ones</i>
10	<i>1 ten</i> × <i>3 tens</i>	<i>1 ten</i> × <i>3 ones</i>

	3 3
×	1 5
<hr/>	
	1 5
	1 5 0
	3 0
+	3 0 0
<hr/>	
	4 9 5

I write the expressions that represent the areas of the four smaller rectangles. I record each partial product vertically. I find the sum of the areas of the four smaller rectangles.

3. Visualize the area model, and solve the following numerically using four partial products. (You may sketch an area model if it helps.)

	3 7
×	1 3
<hr/>	
	2 1
	9 0
	7 0
+	3 0 0
<hr/>	
	1
	4 8 1

	30	7
3	<i>3 ones</i> × <i>3 tens</i>	<i>3 ones</i> × <i>7 ones</i>
10	<i>1 ten</i> × <i>3 tens</i>	<i>1 ten</i> × <i>7 ones</i>

To solve, I visualize the area model. I record the partial products. I find the total.

G4-M3-Lesson 37

1. Solve 37×54 using 4 partial products and 2 partial products. Remember to think in terms of units as you solve. Write an expression to find the area of each smaller rectangle in the area model. Match each partial product to its area on the models.

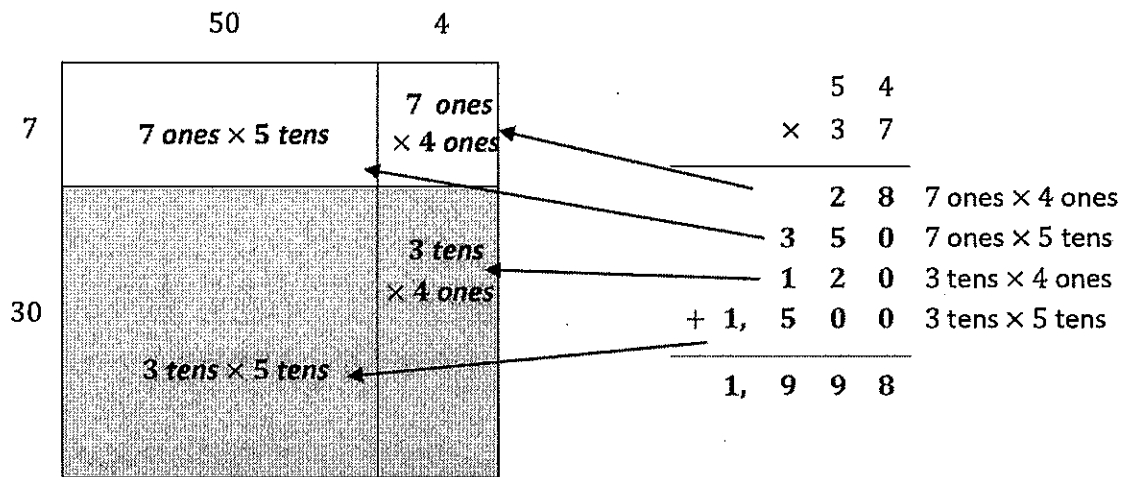

I solve using 4 partial products. This is just like what I did in Lesson 36.

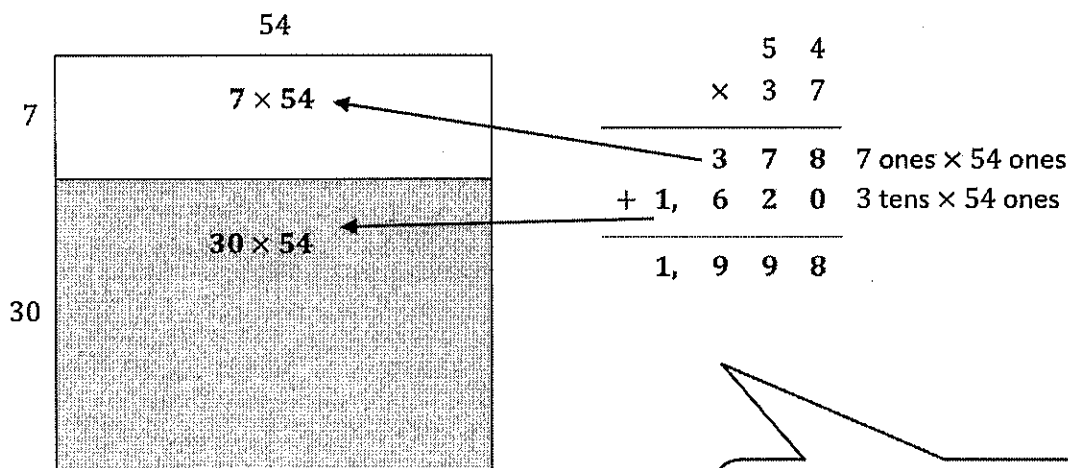

To show 2 partial products, I combine the values of the top two rectangles, and I combine the values of the bottom two rectangles.

I know one partial product is represented by the white portion of the large rectangle. The other partial product is represented by the shaded portion.

2. Solve 38×46 using 2 partial products and an area model. Match each partial product to its area on the model.

$$\begin{array}{r}
 46 \\
 \times 38 \\
 \hline
 368 \\
 + 1,380 \\
 \hline
 1,748
 \end{array}$$

$8 \text{ ones} \times 46 \text{ ones}$
 $3 \text{ tens} \times 46 \text{ ones}$

$$\begin{array}{r}
 46 \\
 \times 8 \\
 \hline
 368 \\
 \hline
 46 \\
 \times 30 \\
 \hline
 180 \\
 + 1,200 \\
 \hline
 1,380
 \end{array}$$

I solve for the partial products, and then I find their sum.

3. Solve the following using 2 partial products. Visualize the area model to help you.

$$\begin{array}{r}
 74 \\
 \times 25 \\
 \hline
 370 \\
 + 1,480 \\
 \hline
 1,850
 \end{array}$$

5×74
 20×74

$$\begin{array}{r}
 74 \\
 \times 5 \\
 \hline
 370 \\
 \hline
 74 \\
 \times 20 \\
 \hline
 80 \\
 + 1,400 \\
 \hline
 1,480
 \end{array}$$

I visualize the 2 partial products of $5 \text{ ones} \times 74$ and $2 \text{ tens} \times 74$. I solve for the partial products and then find their sum.

