

Homework Helpers

Grade 1 Module 4

Handwritten text or markings along the right edge of the page, possibly bleed-through from the reverse side.

G1-M4-Lesson 1

1. Circle groups of 10. Write the number to show the total amount of objects.

a.

There are 34 peanuts.

b.

There are 23 carrots.

I circle groups of ten. I count the tens first and then the ones. 2 tens 3 ones is 23.

2. Make a number bond to show tens and ones. Circle tens to help. Write the number to show the total amount of objects.

a.

28

/

20

+

8

b.

39

/

30

+

9

I think 10, 20, and 8 is 28.

When I count with ten-sticks, it's much quicker to count. 10, 20, 30, 31, 32, 33, ..., 39.

Make or complete a math drawing to show tens and ones. Complete the number bonds.

3.

4.

35 is made of 3 tens and 5 extra ones.

G1-M4-Lesson 2

Write the tens and ones. Complete the statement.

1.

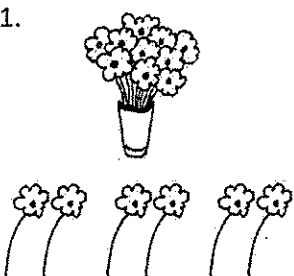

tens	ones
1	6

There are 16 flowers.

In the number 16, the 1 stands for 1 ten. The 6 stands for 6 ones.

Write the tens and ones. Complete the statement.

2.

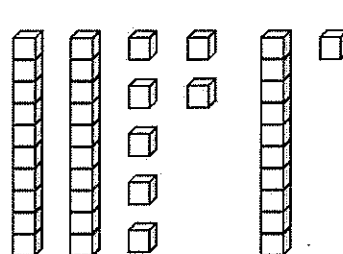

tens	ones
3	8

There are 38 cubes.

38 can be separated into 2 parts: 30 and 8. I have 3 ten-sticks and 8 extra ones.

Write the missing numbers. Say them the regular way and the Say Ten way.

3.

tens	ones
2	7



27

I look at the place value chart. 2 tens and 7 ones is 27. I can say it the Say Ten way: 2 tens 7.

4. Choose a number less than 40. Make a math drawing to represent it. Fill in the number bond and place value chart.

tens	ones
2	4

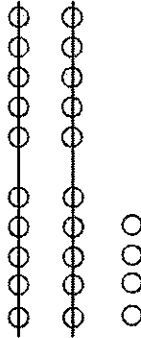
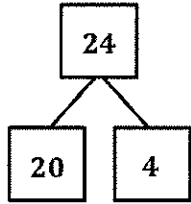

I can make a 5-group column drawing. I draw 2 tens and 4 ones. 24 is 20 and 4.

G1-M4-Lesson 3

1. Count as many tens as you can. Complete the statement. Say the numbers and the sentences.



2 tens 6 ones is the same as 26 ones.

I see 26 as 2 tens and 6 extra ones. I count by tens first. 10, 20, and 6 ones is 26.

Fill in the missing numbers.

2.	<u>27</u>	➡	<table border="1" style="display: inline-table;"> <tr><th>tens</th><th>ones</th></tr> <tr><td>2</td><td>7</td></tr> </table>	tens	ones	2	7	➡	<u>27</u> ones
tens	ones								
2	7								
3.	<u>38</u>	➡	8 ones 3 tens	➡	<u>38</u> ones				
4.	<u>30</u>	➡	<u>0</u> ones <u>3</u> tens	➡	30 ones				

The number 27 doesn't have 7 ones. It has 27 ones!

There are 38 ones. Or I can say 38 has 3 tens 8 ones. Each ten is made of 10 ones. So, I can count on by tens to get to 30 and then by ones to get to 38.

5. Choose at least one number less than 40. Draw the number in 3 ways:

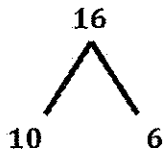
As grapes:	In a number bond:	In the place value chart:				
		<table border="1" style="display: inline-table;"> <tr><th>tens</th><th>ones</th></tr> <tr><td>1</td><td>6</td></tr> </table>	tens	ones	1	6
tens	ones					
1	6					

I draw 1 group of 10 grapes since 16 has 1 ten. Then, I draw 6 extra grapes to show 6 ones. I can think of 16 as 1 ten 6 ones or 16 ones.

G1-M4-Lesson 4

1. Fill in the number bond, or write the tens and ones. Complete the addition sentences.

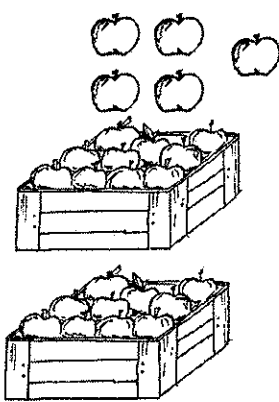
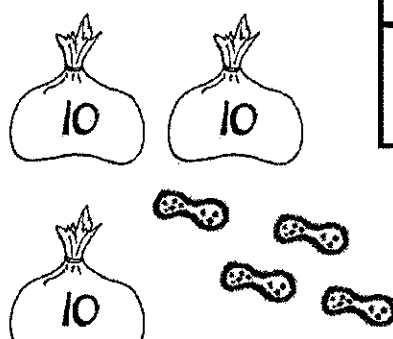
 <div style="display: flex; align-items: center; margin-top: 20px;"> <div style="border: 1px solid black; padding: 5px; margin-right: 10px;">5</div> <div style="font-size: 2em; margin-right: 10px;">}</div> <div style="border: 1px solid black; padding: 5px;">25</div> </div> <div style="display: flex; align-items: center; margin-top: 20px;"> <div style="border: 1px solid black; padding: 5px; margin-right: 10px;">20</div> <div style="font-size: 2em; margin-right: 10px;">}</div> <div style="border: 1px solid black; padding: 5px;">25</div> </div> <p style="text-align: center; margin-top: 20px;">$5 + 20 = \underline{25}$</p> <p style="text-align: center;">20 more than 5 is <u>25</u>.</p>	<div style="display: flex; align-items: center; margin-bottom: 20px;">  <table border="1" style="margin-left: 20px; text-align: center;"> <thead> <tr> <th>tens</th> <th>ones</th> </tr> </thead> <tbody> <tr> <td>3</td> <td>4</td> </tr> </tbody> </table> </div> <p style="text-align: center; margin-top: 20px;">$\underline{30} + \underline{4} = \underline{34}$</p>	tens	ones	3	4
tens	ones				
3	4				

I can make a number bond that shows the tens and ones. I can break apart 25 into 20 and 5.

3 tens 4 ones is the same as the number 34. 3 is the digit in the tens place, and 4 is the digit in the ones place.

2. Match the pictures with the words.

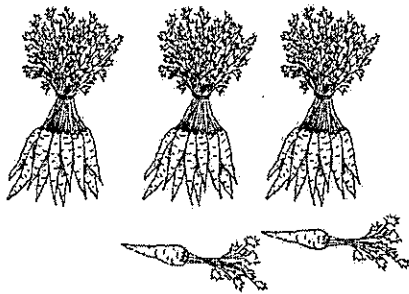
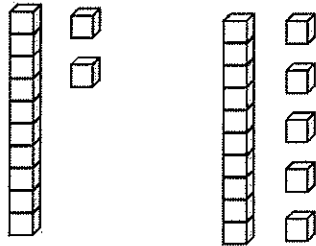

This statement combines tens and ones!

2 more than 30 is 32.

$$20 + 7 = 27$$

I can write a number sentence with the tens first, or I can write it with the ones first, like $7 + 20 = 27$. One number tells how many tens there are, and the other tells how many ones there are.

G1-M4-Lesson 5

Draw quick tens and ones to show the number. Then draw 1 more or 10 more.

1.

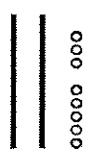

1 more than 27 is 28.

2.

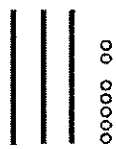

10 more than 27 is 37.

I can show 27 with 2 quick tens and 7 ones in a 5-group column. To figure out 1 more, I add 1 circle to the ones, so 7 ones becomes 8 ones.

Look at how quickly I can draw 37. A quick ten is a line that holds 10 beads! It represents a ten. I can draw one more quick ten to show 10 more than 27.

Draw quick tens and ones to show the number. Cross off (x) to show 1 less or 10 less.

3.

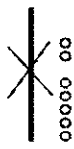

10 less than 17 is 7.

4.



1 less than 25 is 24.

I can cross out a quick ten when I want to show 10 less than 17. Now, there are no tens and 7 ones.

Match the words to the picture that shows the right amount.

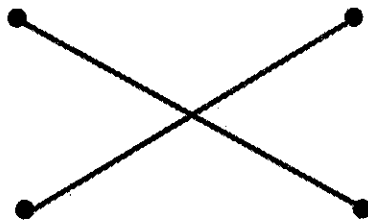
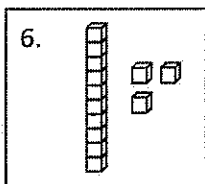
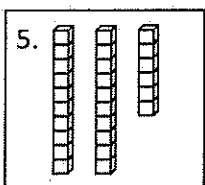

10 less than 23

10 more than 16

The digit in the tens place changes when I think of 10 more than 16. The new number is 26. That's 2 tens 6 ones.

G1-M4-Lesson 6

Fill in the place value chart and the blanks.

1.

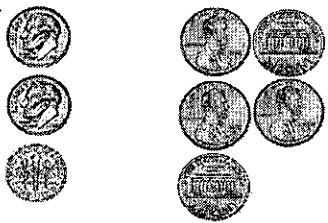

dimes	pennies
3	5

35 = 3 tens 5 ones

2.



dimes	pennies
0	6

6 = 0 tens 6 ones

1 dime has the same value as 10 pennies, but it's just 1 coin. 3 dimes and 5 pennies equal 3 tens 5 ones. That's 35 cents!

I don't see any tens because there are no dimes. The value of 6 pennies is 6 cents.

Fill in the blank. Draw or cross off tens or ones as needed.

3.



10 more than 30 is 40.

4.



1 less than 24 is 23.

I can draw 1 more dime since I want to show 10 more. So, 3 tens changes to 4 tens.
 $30 \text{ cents} + 10 \text{ cents} = 40 \text{ cents}$.

When I cross off 1 penny, I have 1 less, or 23 cents. I could write this in my place value chart as 2 tens 3 ones.

G1-M4-Lesson 7

Write the number, and circle the set that is *greater* in each pair. Say a statement to compare the two sets.

1.

30
29

I look at the tens place first to find the number that is greater. 3 tens is more than 2 tens. So, 30 is greater than 29.

Circle the number that is *greater* for each pair.

2.

3 tens 9 ones
4 tens 8 ones

4 tens is greater than 3 tens, so 48 is greater than 39.

Write the number, and circle the set that is *less* in each pair. Say a statement to compare the two sets.

3.

28
27

First, I look at the tens place and both numbers have 2 tens. Next, I look at the ones place, and 7 ones is less than 8 ones. So, 27 is less than 28.

4. Write the value, and circle the set of coins that has *less* value.

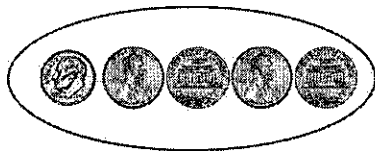

14 cents



22 cents

The first set has 5 coins, and the second set has 4 coins, but you have to look at the values! Dimes and pennies are like tens and ones. So, 1 ten 4 ones is less than 2 tens 2 ones.

5. Maddox and Caroline are playing cards. If Caroline's total has 29 ones and Maddox's total is 26, whose total is less? Draw a math drawing to explain how you know.

Hey, 29 ones is also 2 tens 9 ones! I can draw a picture and just compare ones!

C

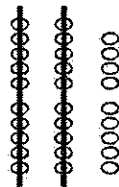

M

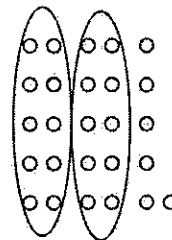

Maddox's total is less. I know because they both have 2 tens, so I looked at the ones. Maddox only has 6 ones, and Caroline has 9 ones. So, Maddox has less.

G1-M4-Lesson 8

1. Draw the numbers using quick tens and circles. Use the phrases from the word bank to complete the sentence frames to compare the numbers.

Word Bank

is greater than
is less than
is equal to

a.

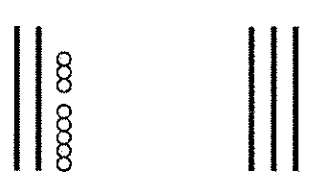

28 is less than 30.

b.



1 ten 7 ones is equal to 17.

I look at the digit in the tens place first to compare the numbers! Even though there are 8 ones in 28, that's still less than a ten. I read from left to right: 28 is less than 30.

3 tens 3 ones is 33. Both numbers have 3 tens, but 3 ones is less than 4 ones. So, 3 tens 3 ones is less than 34.

2. Circle the numbers that are *less than* 34.

29 3 tens 5 ones 4 tens
 31 3 tens 3 ones

3. Write the numbers in order from *greatest to least*.

	24	
12		40
	16	

I read the numbers from left to right. 40 is greater than 24. 24 is greater than 16....

40 24 16 12

Where would the number 38 go in this order? Use words or rewrite the numbers to explain.

40 38 24 16 12

I put 38 between 40 and 24. 38 is less than 40, and 38 is greater than 24. Look at the tens: 4 tens, 3 tens, 2 tens!

G1-M4-Lesson 9

1. Write the numbers in the blanks so that the alligator is eating the greater number. Read the number sentence, using *is greater than*, *is less than*, or *is equal to*. Remember to start with the number on the left.

a.

23		28
28		23

b.

29		30
29		30

I remember to read starting with the number on the left. So, 28 is greater than 23. I know because 2 tens 8 ones is greater than 2 tens 3 ones.

29 is less than 30. 30 is 3 tens! The alligator wants to eat the bigger number!

2. Complete the charts so that the alligator is eating a *greater* number.

a.

<table border="1" style="border-collapse: collapse; width: 60px; height: 60px;"> <tr><th style="padding: 2px;">tens</th><th style="padding: 2px;">ones</th></tr> <tr><td style="text-align: center; padding: 5px;">1</td><td style="text-align: center; padding: 5px;">5</td></tr> </table>	tens	ones	1	5			<table border="1" style="border-collapse: collapse; width: 60px; height: 60px;"> <tr><th style="padding: 2px;">tens</th><th style="padding: 2px;">ones</th></tr> <tr><td style="text-align: center; padding: 5px;">1</td><td style="text-align: center; padding: 5px;">3</td></tr> </table>	tens	ones	1	3
tens	ones										
1	5										
tens	ones										
1	3										

b.

<table border="1" style="border-collapse: collapse; width: 60px; height: 60px;"> <tr><th style="padding: 2px;">tens</th><th style="padding: 2px;">ones</th></tr> <tr><td style="text-align: center; padding: 5px;">2</td><td style="text-align: center; padding: 5px;">3</td></tr> </table>	tens	ones	2	3			<table border="1" style="border-collapse: collapse; width: 60px; height: 60px;"> <tr><th style="padding: 2px;">tens</th><th style="padding: 2px;">ones</th></tr> <tr><td style="text-align: center; padding: 5px;">2</td><td style="text-align: center; padding: 5px;">8</td></tr> </table>	tens	ones	2	8
tens	ones										
2	3										
tens	ones										
2	8										

I read the number sentence as 15 is greater than 13. Both numbers have 1 ten, but 5 ones is bigger than 3 ones, so the alligator eats the number

I write 8 in the ones place, so the alligator eats the number 28. I can read the number sentence as 23 is less than 28. I could also write 4, 5, 6, 7, 8, or 9 ones,

3. Compare each set of numbers by matching to the correct alligator or phrase to make a true number sentence. Check your work by reading the sentence from left to right.

28 18

13 31

28 30

is less than

is greater than

13 has 1 ten 3 ones.
31 has 3 tens 1 one.
So, 13 is less than 31.

G1-M4-Lesson 10

Use the symbols to compare the numbers. Fill in the blank with $<$, $>$, or $=$ to make a true number sentence. Complete the number sentence with a phrase from the word bank.

a.

21 $>$ 12

21 is greater than 12.

Both of these numbers have the same digits, but they are in different positions. That means they have a different value. 2 tens 1 one is greater than 1 ten 2 ones!

Word Bank

is greater than

is less than

is equal to

b.

3 tens $<$ 32

3 tens is less than 32.

I put the less than sign between 3 tens and 32. 3 tens is 30. The smaller end points to the smaller number!

c.

2 tens 8 ones $<$ 29

2 tens 8 ones is less than 29.

There are more ones in 29 than in 2 tens 8 ones, or 28. The symbol is open on the side that the alligator likes to eat! But I still read it from left to right!

d.

19 $=$ 1 ten 9 ones

19 is equal to 1 ten 9 ones.

G1-M4-Lesson 11

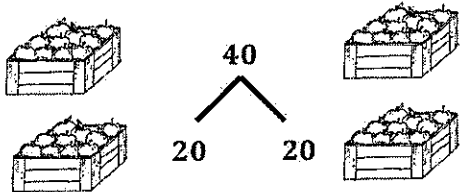
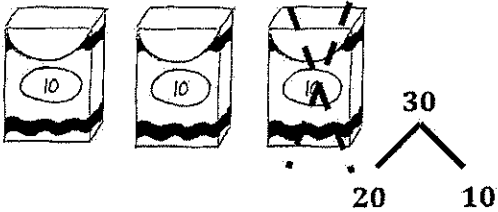

Draw a number bond, and complete the number sentences to match the pictures.

<p>1.</p>  <p style="text-align: center;"> $\underline{4}$ tens = $\underline{2}$ tens + $\underline{2}$ tens $\underline{40} = \underline{20} + \underline{20}$ </p>	<p>2.</p>  <p style="text-align: center;"> $\underline{3}$ tens - $\underline{1}$ ten = $\underline{2}$ tens $\underline{30} - \underline{10} = \underline{20}$ </p>
---	---

I can say the number sentence with place value units, so 4 tens = 2 tens + 2 tens. That's the unit way. Or I can just write the numbers the regular way, so $40 = 20 + 20$.

The number bond shows 3 tens on top with 2 tens and 1 ten as the parts. The X shows that I take away 1 ten. The subtraction sentences match.

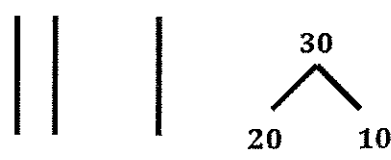
Draw quick tens and a number bond to help you solve the number sentences.

<p>3.</p>  <p style="text-align: center;"> $20 + 10 = \underline{30}$ </p>	<p>4.</p>  <p style="text-align: center;"> $40 - 10 = \underline{30}$ </p>
--	---

I can draw 4 quick tens to show 40. I cross off 1 ten. There are 3 tens left, or 30.

2 tens + 1 ten = 3 tens. It's just like $2 + 1 = 3$, except now it's tens. The units change!

Add or subtract.

5. $4 \text{ tens} - 3 \text{ tens} = \underline{1 \text{ ten}}$

6. $\underline{40} = 10 + 30$

I can think of the simpler problem,
 $4 = 1 + 3$, to help me solve.

7. $20 - 20 = \underline{0}$

G1-M4-Lesson 12

1. Fill in the missing numbers to match the picture. Write the matching number bond.

a.

$$\begin{array}{c} 32 \\ \swarrow \quad \searrow \\ 12 \quad 20 \end{array}$$

$$\underline{12} + \underline{20} = \underline{32}$$

b.

$$\begin{array}{c} 39 \\ \swarrow \quad \searrow \\ 29 \quad 10 \end{array}$$

$$\underline{29} + \underline{10} = \underline{39}$$

1 ten 2 ones + 2 tens = 3 tens 2 ones. The digit in the tens place changes because I add 2 tens. The ones stay the same.

1 ten more than 2 tens is 3 tens. That's why there is a 3 in the tens place. There are still 9 ones.

2. Draw using quick tens and ones. Complete the number bond and the number sentence.

a.

tens	ones
2	3

+

tens	ones
1	0

$$\begin{array}{c} 33 \\ \swarrow \quad \searrow \\ 23 \quad 10 \end{array}$$

$$\underline{23} + \underline{10} = \underline{33}$$

b.

tens	ones
1	4

+

tens	ones
2	0

$$\begin{array}{c} 34 \\ \swarrow \quad \searrow \\ 14 \quad 20 \end{array}$$

$$\underline{14} + \underline{20} = \underline{34}$$

The number bond shows how I change 23 to make 33. I add 1 ten.

If 34 is the whole and 14 is one part, I can add 2 tens to make 34. 2 tens is the same as 20. 14 plus 20 equals 34.

3. Use arrow notation to solve.

a.

17	<div style="border: 1px solid black; display: inline-block; padding: 2px 5px;">+10</div>	→	27
----	--	---	----

b.

19	<div style="border: 1px solid black; display: inline-block; padding: 2px 5px;">+20</div>	→	39
----	--	---	----

I can think: What number plus 2 tens will give me 3 tens 9 ones? 1 ten 9 ones plus 2 tens equals 3 tens 9 ones! So, 19 is the number.

4. Use the dimes and pennies to complete the place value charts.

a.



tens	ones	+	tens	ones	=	tens	ones
2	6		1	0		3	6

2 dimes and 6 pennies make 2 tens 6 ones. When I add 1 dime, I add 1 ten. Now, there are 3 tens all together. The number sentence is $26 + 10 = 36$.

G1-M4-Lesson 13

1. Use quick tens and ones to complete the place value chart and number sentence.

I can show 26 with 2 quick tens and 6 dots, or circles. I can show adding 4 using x's. 6 and 4 make a new ten! Let me put a line through these to show it's a ten. Now I have 3 tens!

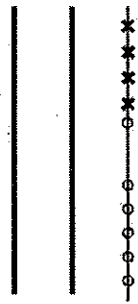

tens	ones
3	0

$$26 + 4 = \underline{30}$$

2. Draw quick tens, ones, and number bonds to solve. Complete the place value chart.

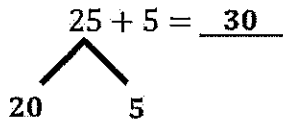

tens	ones
3	0

25 is made of 20 and 5. I can add 5 and 5 to make 10. Then I know that $20 + 10 = 30$. That's 3 tens.

3. Solve. You may draw quick tens and ones or number bonds to help.

$$37 + 3 = \underline{40}$$

I know this one in my head. 3 more than 37 is 40. I am making the next ten when I add 3 to 37.

G1-M4-Lesson 14

1. Use the pictures, or draw quick tens and ones. Complete the number sentence and place value chart.

I can use 2 quick tens and 9 dots, or circles, to show 29. I only need one more to make a new ten. As I add 5, the first x makes a new ten. I start a new column as I draw 4 more x's. I can draw a line through the new ten I made. Now I can see easily that I have 3 tens and 4 ones.

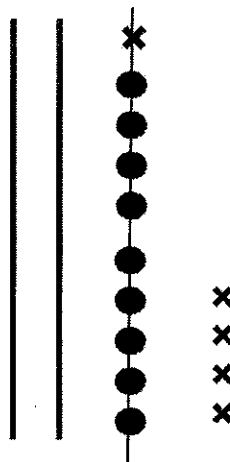

tens	ones
3	4

$29 + 5 = \underline{34}$

2. Make a number bond to solve. Show your thinking with number sentences or the arrow way. Complete the place value chart.

I need 2 more to get to 20 from 18. I can break apart 5 into 2 and 3. $18 + 2 = 20$. Then $20 + 3 = 23$.

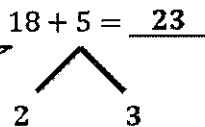

tens	ones
2	3

Here are my number sentences to show my thinking.

$18 + 2 = 20$
 $20 + 3 = 23$

$18 \xrightarrow{+2} 20 \xrightarrow{+3} 23$

I can use the arrow way to show my thinking too! I start at 18. I add 2 to get to 20. Then, I add 3 more to get to 23.

G1-M4-Lesson 15

1. Solve the problems.

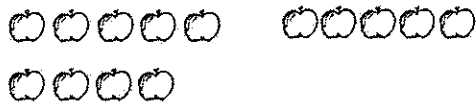

$$9 + 5 = \underline{14}$$

9 plus 5 is 14.
That one's easy.

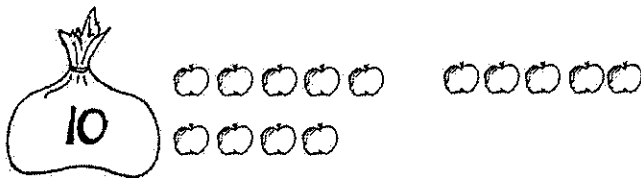

$$19 + 5 = \underline{24}$$

19 plus 5 is just 10 more.
That's 24.

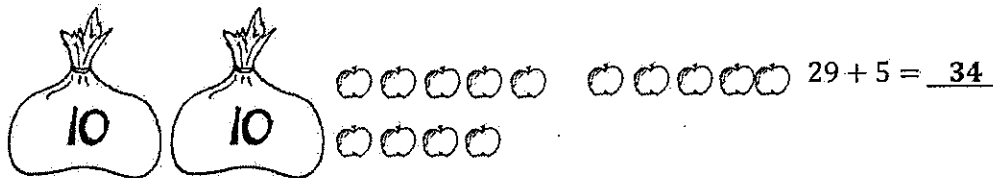

$$29 + 5 = \underline{34}$$

29 plus 5 is 10 more again.
That's 34.

2. Use the first number sentence in each set to help you solve the other problems.

a. $3 + 8 = \underline{11}$

b. $13 + 8 = \underline{21}$

c. $23 + 8 = \underline{31}$

3. Solve the problems. Show the 1-digit addition sentence that helped you solve.

$$18 + 4 = \underline{22}$$

$$\underline{8 + 4 = 12}$$

I can use $8 + 4$ to help me solve $18 + 4$. I know that $8 + 4 = 12$. $18 + 4$ has 1 more ten. That's 22.

G1-M4-Lesson 16

1. Draw quick tens and ones to help you solve the addition problems.



$13 + 2 = \underline{15}$

I can draw 13 with 1 quick ten and 3 dots or circles. I need to add 2 x's. That's 15.

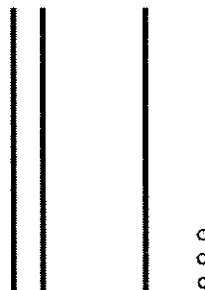

$13 + 20 = \underline{33}$

This time, I'm adding 20, and that's 2 tens. I can add 2 quick tens to my drawing of 13. Now, I have 33.

2. Make a number bond, or use the arrow way to solve the addition problems.

$11 + 20 = \underline{31}$

I can solve this in different ways!

$11 \xrightarrow{+10} 21 \xrightarrow{+10} 31$

I can break apart 11 into 10 and 1. Then, I can add my tens. That's 3 tens, or 30, and 1 one to make 31.

$11 \xrightarrow{+10} 21 \xrightarrow{+10} 31$

I can also start with 11 and add my tens one at a time. $11 + 10 = 21$. Then, when I add another 10, I get to 31.

G1-M4-Lesson 17

1. Use quick ten drawings or number bonds to make true number sentences.

a. $13 + 10 = \underline{23}$

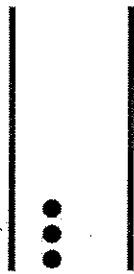

I can draw 13 and then just add another quick ten. Let me count what I have now: 10, 20, ..., 23.

b. $25 + 5 = \underline{30}$



$$5 + 5 = 10$$

$$10 + 20 = 30$$

I can break apart 25 into 20 and 5. I add 5 and 5 to make the next ten. The next ten is 30.

2. How did you solve Problem 1(a)? Why did you choose to solve it that way?

I chose to use a quick ten drawing because I only had to draw 1 more ten. That was a fast way to show $13 + 10 = 23$.

3. How did you solve Problem 1(b)? Why did you choose to solve it that way?

I used a number bond because I wanted to see the parts I had. When I broke apart 25 into 20 and 5, I saw that I could add 5 and 5 to make a new ten.

G1-M4-Lesson 18

1. Two students both solved the addition problem below using different methods. Are they both correct? Why or why not?

$$28 + 5 = \underline{33}$$

$$28 \xrightarrow{+2} 30 \xrightarrow{+3} 33$$

This student used the arrow way to get the answer. He used 2 to get to 30 and then added 3 more to get to 33. That means he added 5 altogether to get to 33. That's correct.

$$28 + 5 = \underline{33}$$



This student broke apart 5 so she could get to the next 10. She needed 2 to get to 30. Then she added the rest and got to 33. That's correct.

They are both correct. 28 plus 5 is 33. The first student used the arrow way to show his thinking. That student added 2 to get to 30 and then added 3 more since he had to add 5 altogether. The second student used a number bond to show how she got to 33.

2. Another two students solved the same problem shown below, using quick tens. Are they both correct? Why or why not?

$$16 + 2 = \underline{18}$$



I already know $16 + 2 = 18$. When I look at the drawing, it matches the number sentence.

This does not look right. Let me see. I see too many quick tens. I know! This student added 2 tens instead of 2 ones!

$$16 + 2 = \underline{36}$$

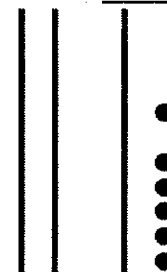

The first student is correct. The second student is not correct. The second student added quick tens instead of ones. He has too much.

3. Circle any student work that is correct.

Student A	Student B	Student C
$13 + 20 = \underline{\quad}$	$16 + 5 = \underline{\quad}$	$17 + 9 = \underline{\quad}$

I know $16 + 3 = 19$ not 20. I can see this is not correct. I can fix it by writing 19 instead of 20. I can then add 2 to 19 and the total is 21.

Fix the student work that was incorrect by making a new drawing or drawings in the space below.

$$16 \xrightarrow{+3} 19 \xrightarrow{+2} 21$$

Choose a correct student work, and give a suggestion for improvement.

Student A's work can be solved without breaking apart 13. I can just add 2 tens to 13. I can do this in my head and get the answer 33.

G1-M4-Lesson 19

Solve using the RDW process.

John has 5 red racecars and 12 blue racecars. How many racecars does John have in all?

I can draw 5 circles for the red racecars. I put my circles in a rectangle to keep them organized. I label my drawing with the number 5 and the letter *R*, so I know that this rectangle represents the 5 red racecars.

I connect the two rectangles and draw a box with a question mark labeled with the letter *T* because it is the total. When I find the total, I will know the answer to the question.

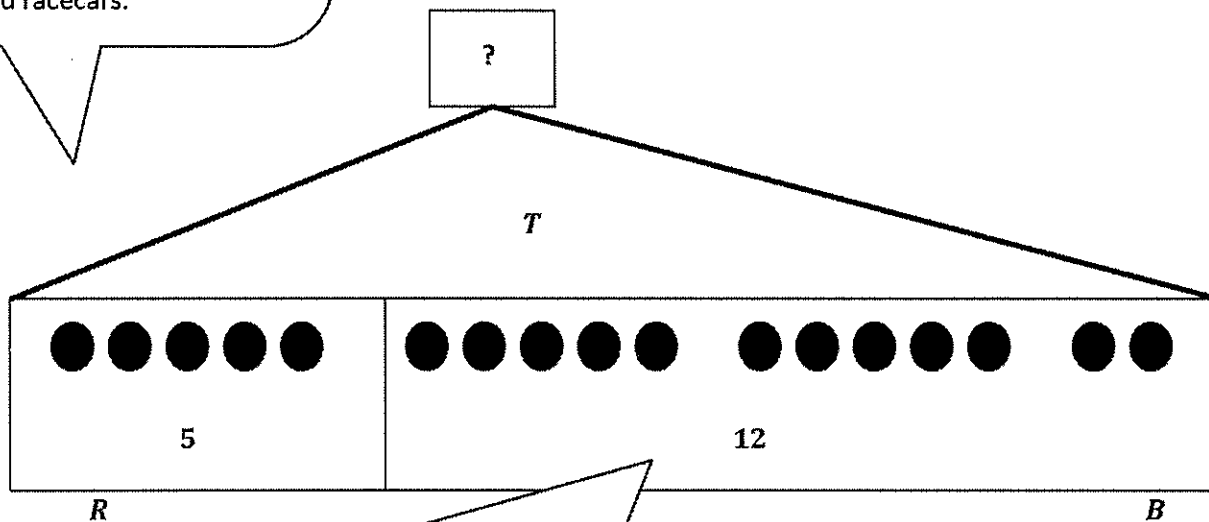

I can draw 12 circles for the blue racecars. I organize my circles and put them in a rectangle labeled with the number 12 and the letter *B*, so I know that this rectangle represents the 12 blue racecars.

$$5 + 12 =$$

17

I draw a box around 17 because it is the total and answers the question. The last part of RDW is write. I can write a statement to answer the question.

John has 17 racecars.

G1-M4-Lesson 20

What can I draw?

Solve using the RDW process.

- Mary has 14 play practices this month. 7 practices are after school, and the rest are in the evening. How many practices are in the evening?

What do I know after reading the problem?

I know the total, or the whole. I can draw 14 circles in 5-group rows to represent the total number of practices.

T

14

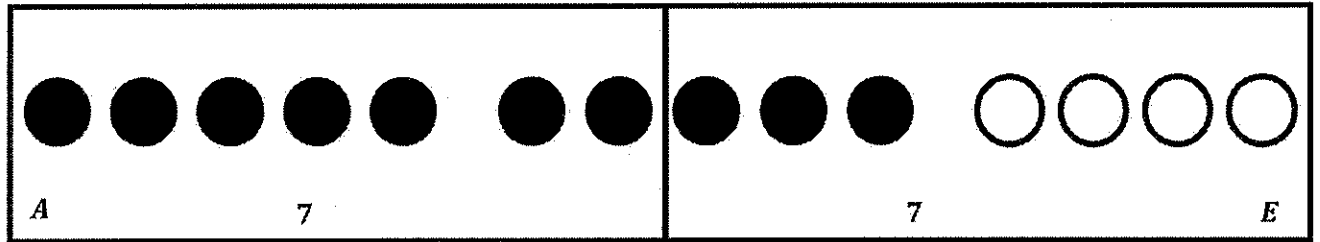

I know there are 7 practices after school. I can draw a rectangle around 7 of the circles to represent the 7 practices that are after school. I label the rectangle with the letter *A* for after school.

I draw a rectangle around the rest of the circles. This represents the practices that are in the evening. I count the circles and see there are 7 practices in the evening. I label the rectangle with the letter *E* for evening.

$$14 - 7 =$$

7

I draw a rectangle around the 7 because 7 is the answer to the question.

Mary has 7 practices in the evening.

2. Katelyn gave some of her stickers to her friend. She had 18 stickers at first, and she still has 12 stickers left. How many stickers did Katelyn give to her friend?

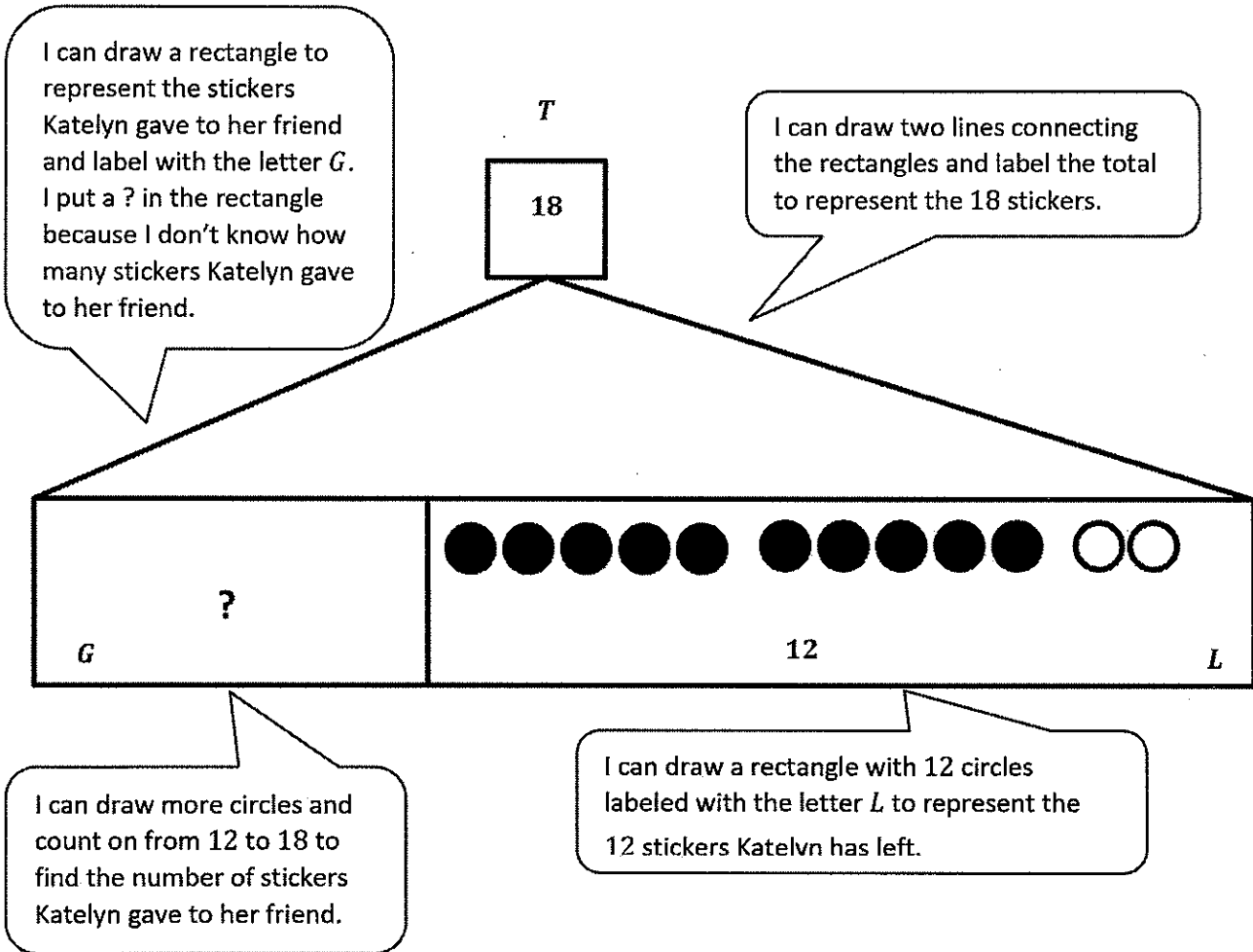

$$\boxed{6} + 12 = 18$$

Katelyn gave 6 stickers to her friend.

G1-M4-Lesson 21

Solve using the RDW process.

Emi made a bracelet that was 13 centimeters long. The bracelet didn't fit so she made the bracelet longer. Now the bracelet is 17 centimeters long. How many centimeters did Emi add to the bracelet?

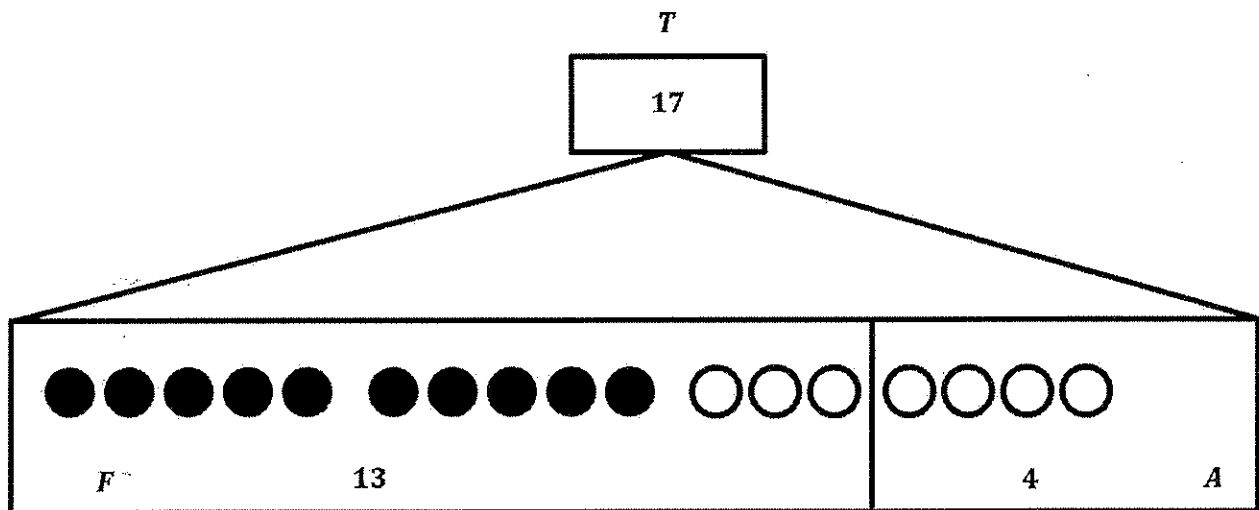

I can draw 13 circles to represent the length of Emi's bracelet at first. I label with the letter *F* for first beads on the bracelet.

I can draw more circles for the length Emi added to her bracelet until the total is 17 beads. I add 4 circles to represent the added length.

$$13 + \boxed{4} = 17$$

Emi added 4 centimeters to the bracelet.

G1-M4-Lesson 22

Use the tape diagrams to write a variety of word problems. Use the word bank, if needed. Remember to label your model after you write the story.

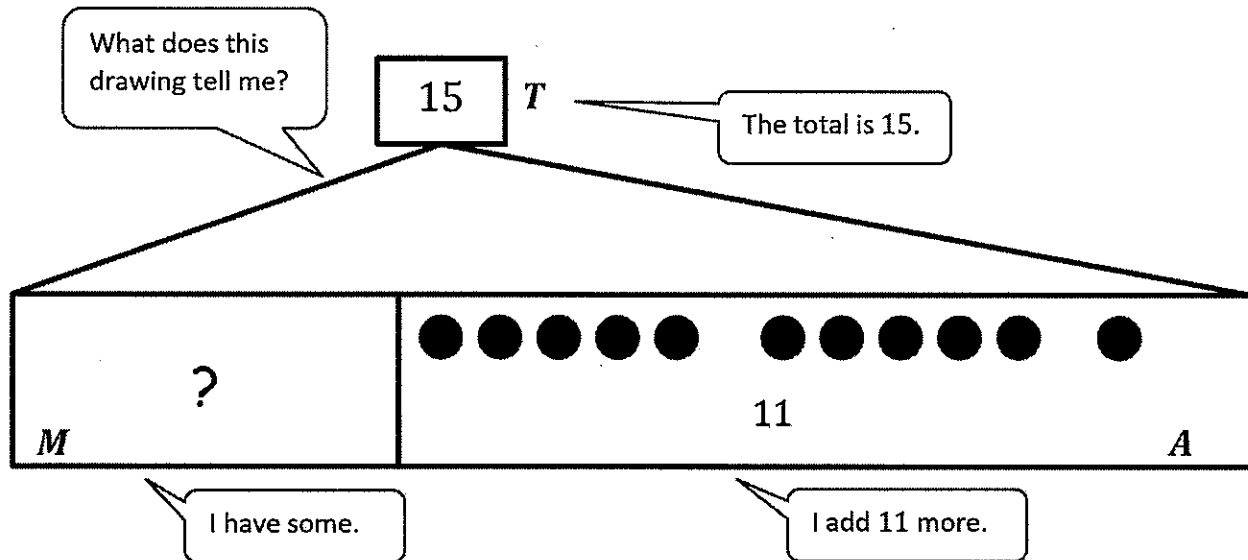

Topics (Nouns)		
flowers	goldfish	lizards
stickers	rockets	cars
frogs	crackers	marbles

Actions (Verbs)		
hide	eat	go away
give	draw	get
collect	build	play

I can use the words in the box to help me think of what to write, or I can think of my own idea.

Beth picks some flowers for her mom in the morning. She picks 11 more flowers in the afternoon. Now she has 15 flowers for her mom. How many flowers did Beth pick in the morning?

G1-M4-Lesson 23

1. Fill in the blanks, and match the pairs that show the same amount.

I can match these pictures because they both show 32. 3 tens 2 ones is equal to 2 tens 12 ones. If I bundle 10 ones in the picture on the right, it would have 3 tens 2 ones.

3 tens 2 ones

2 tens 12 ones

2. Match the place value charts that show the same amount.

The place value chart shows how many tens and ones. It's okay to have more than 9 in the ones. 2 tens 15 ones is 35.

tens	ones
3	5

tens	ones
3	7

tens	ones
0	37

tens	ones
2	15

3 tens 7 ones is the same as 37 ones. I can unbundle the 3 tens, which makes 30 ones. I add the 7 ones, and now I have 37 ones.

3. Emi says 29 is the same as 1 ten 19 ones, and Ben says 29 is the same as 2 tens 19 ones. Draw quick tens to show if Emi or Ben is correct.

Emi

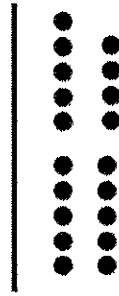

Ben

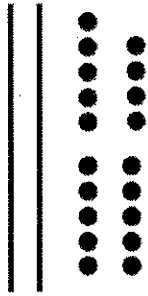



One straight line is a quick ten. I draw 1 quick ten and 19 ones for Emi's drawing. I draw 2 quick tens and 19 ones for Ben's drawing.

Emi is correct because 1 ten 19 ones is the same as 29. Ben is not correct because 2 tens 19 ones is the same as 39, which is not 29.

G1-M4-Lesson 24

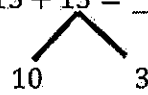
1. Solve using number bonds. Write the two number sentences that show that you added 10 first. Draw quick tens and ones if that helps you.

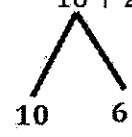
<p>a.</p> $15 + 13 = \underline{28}$  <div style="display: flex; align-items: center; margin-top: 10px;"> <div style="margin-right: 20px;">  </div> <div> $15 + 10 = 25$ $25 + 3 = 28$ </div> </div>	<p>b.</p> $16 + 23 = \underline{39}$  <div style="margin-top: 10px;"> $23 + 10 = \underline{33}$ $\underline{33} + 6 = \underline{39}$ </div>
--	--

I draw 15 using quick tens and ones. I can break apart 13 into 10 and 3. I add 15 and 10, which equals 25. I add the 3 ones to 25. I use x's to show I am adding the 3 ones.

I want to add 10 first, so I break apart 16 into 10 and 6 using a number bond. I add 10 to 23 and get 33. Then, I add 33 and 6, which is my answer of 39.

2. Solve using number bonds.

<p>a.</p> $\begin{array}{r} 17 + 23 = \underline{40} \\ \wedge \\ 10 \quad 7 \end{array}$ <p>$23 + 10 = 33$ $33 + 7 = 40$</p>	<p>b.</p> $\begin{array}{r} 22 + 18 = \underline{40} \\ \wedge \\ 10 \quad 8 \end{array}$
---	---

I can break apart 17 into 10 and 7 using a number bond. I add 10 and 23, which equals 33. Then, I add 33 and 7 to get my answer of 40.

I didn't write the two number sentences because I was able to add in my head.

G1-M4-Lesson 25

1. Solve using number bonds. This time, add the tens first. Write the two number sentences to show what you did.

<p>a.</p> $12 + 16 = \underline{28}$ <div style="text-align: center;"> \wedge 10 2 </div> <div style="text-align: right; margin-top: 20px;"> $16 + 10 = 26$ $26 + 2 = 28$ </div>	<p>b.</p> $23 + 17 = \underline{40}$ <div style="text-align: center;"> \wedge 10 7 </div> <div style="text-align: right; margin-top: 20px;"> $23 + 10 = 33$ $33 + 7 = 40$ </div>
---	---

I need to add the tens first. I can break apart 12 into 10 and 2 and add 10 to 16 first. $10 + 16 = 26$. I still have 2 more to add: $26 + 2 = 28$.

2. Solve using number bonds. This time, add the ones first. Write the two number sentences to show what you did.

<p>a.</p> $23 + 16 = \underline{39}$ <div style="text-align: center;"> \wedge 6 10 </div> <div style="text-align: right; margin-top: 20px;"> $23 + 6 = 29$ $29 + 10 = 39$ </div>	<p>b.</p> $11 + 29 = \underline{40}$ <div style="text-align: center;"> \wedge 10 1 </div> <div style="text-align: right; margin-top: 20px;"> $29 + 1 = 30$ $30 + 10 = 40$ </div>
---	---

I can still break apart 16 into 6 and 10, but this time I add the 6 ones to 23 first.

I notice that when I add my ones, the result is the next 10.

G1-M4-Lesson 26

1. Solve using a number bond to add ten first. Write the two addition sentences that help you.

I need to use the add ten first strategy. I break apart one of the numbers into 10 and some ones.

<p>a. $25 + 14 = \underline{39}$</p> <p style="margin-left: 40px;"> $\begin{array}{c} \diagup \quad \diagdown \\ 10 \quad 4 \end{array}$ </p> <p>$25 + 10 = \underline{35}$</p> <p>$\underline{35} + \underline{4} = \underline{39}$</p>	<p>b. $19 + 15 = \underline{34}$</p> <p style="margin-left: 40px;"> $\begin{array}{c} \diagup \quad \diagdown \\ 10 \quad 5 \end{array}$ </p> <p>$19 + 10 = \underline{29}$</p> <p>$\underline{29} + \underline{5} = \underline{34}$</p>
--	--

Adding 10 to a number is easy. I know $25 + 10 = 35$.
Now I just have to add the ones; that's easy too.

2. Solve using a number bond to make a ten first. Write the two number sentences that help you.

<p>a.</p> $\begin{array}{c} 16 + 19 = 35 \\ \swarrow \quad \searrow \\ 15 \quad 1 \end{array}$ $\begin{array}{r} 19 + 1 = 20 \\ 20 + 15 = 35 \end{array}$	<p>b.</p> $\begin{array}{c} 18 + 14 = 32 \\ \swarrow \quad \searrow \\ 2 \quad 12 \end{array}$ $\begin{array}{r} 18 + 2 = 20 \\ 20 + 12 = 32 \end{array}$
---	---

16 is broken apart into 15 and 1 because 19 needs 1 more to make the next ten.

I could have also chosen to break apart 18 into 6 and 12 because I can make the next ten with 6 and 14.

G1-M4-Lesson 27

For the following problems, solve using the strategy that makes you feel most comfortable.

1. $15 + 17 = \underline{32}$



$17 + 10 = 27$

$27 + 5 = 32$

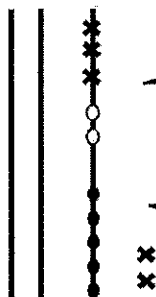

I feel more comfortable using quick tens and ones. I can draw 17 with one quick ten and 7 ones. I draw the ones with 5 closed circles and 2 open circles, to help me see how many more 7 needs to make a new ten.

I can break apart 15 into 10 and 5, and add a quick ten next to the quick ten in 17. Now I only have 5 more to add. I use x's to draw this part to help keep track of how many I need to draw. I add 3 x's to the 7 ones in 17. I draw a line through the circles and x's because 7 and 3 makes a ten, I have 2 more to draw, I can draw 2 more x's. My drawing shows 32.

2. $18 + 14 = \underline{32}$

$18 + 10 = 28$

$28 + 4 = 32$

For this problem, I feel most comfortable using the add ten first strategy, which means I break apart 14 into 10 and 4, and then I add 10 and 18 which makes 28. I have 4 more to add. 28 and 4 is 32.

3. $19 + 12 = \underline{31}$

$19 + 2 = 21$

$21 + 10 = 31$

For this problem, I feel most comfortable adding the ones first. 12 is ten and 2. I can add the 2 to 19, which makes 21. Then, I can quickly add the 10 to get the answer.

4. $19 + 18 = \underline{37}$

$19 + 1 = 20$

$20 + 17 = 37$

For this problem, I feel most comfortable making a 10. I know that 19 needs one more to make 20. I can easily break apart 18 into 1 and 17.

G1-M4-Lesson 28

Solve using quick tens and ones, number bonds, or the arrow way.

1. $26 + 13 = \underline{39}$

$$26 \xrightarrow{+10} 36 \xrightarrow{+3} 39$$

I solved using the arrow way because I know 13 is 10 and 3. I can add the 10 first to get 36 and then add 3. My answer is 39.

2. $18 + 18 = \underline{36}$

$$\begin{array}{c} \diagup \quad \diagdown \\ 2 \quad 16 \end{array}$$

$$18 + 2 = 20$$

$$20 + 16 = 36$$

I solved using a number bond. I made a ten. I know 18 needs 2 more to make 20, so I broke apart the other 18 into 2 and 16. I added 20 and 16 to get my answer of 36.

3. $22 + 18 = \underline{40}$



I solved using quick tens and ones. I can draw 2 quick tens and 2 ones. I can draw 18 more. 18 is 1 ten and 8 ones.

I can draw the 2 ones in 22 with circles and the 8 ones in 18 with x's. When I do this I make a new ten and draw a line through it.

G1-M4-Lesson 29

Solve using quick tens and ones, number bonds, or the arrow way.

1. $24 + 16 = \underline{40}$

$$\begin{array}{r} 24 \xrightarrow{+10} 34 \xrightarrow{+6} 40 \end{array}$$

I solved using the arrow way because I know 16 is 10 and 6. I can add the 10 to 24 first to get 34. I know that 34 and 6 is 40.

2. $17 + 12 = \underline{29}$

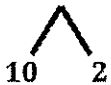

I solved using a number bond. I added 17 and 10 and got 27. Then I added 27 and 2 to get my answer of 29. I didn't need to write the number sentences because I can do the math in my head.

I didn't solve any using drawings this time. Using the arrow way and number bonds is more efficient for me now. If I get stuck I can always use a quick ten drawing.